

**MYCENTER**<sup>®</sup>

**HX400iG/500**

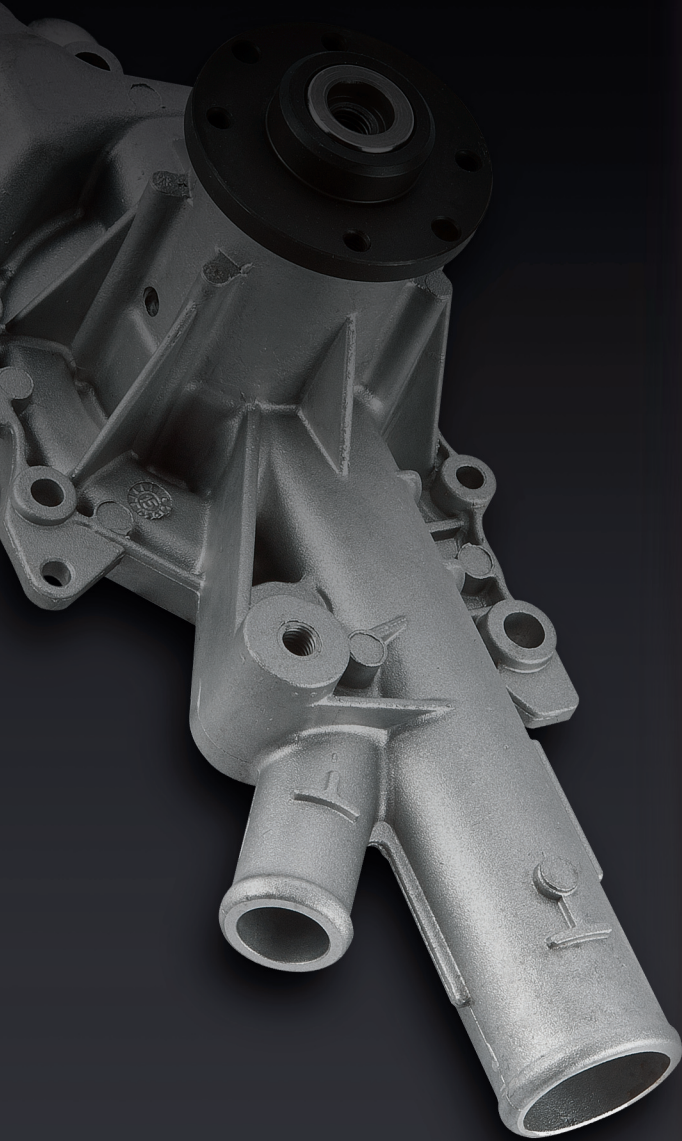

**HORIZONTAL** MACHINING CENTER

**SIMPLIFY THE COMPLICATED**

# HX400iG/500 World's fastest 400m

## Superior design and required precision

- Rigid 9,800kg (21,560Lbs) Meehanite cast construction manufactured in Japan with craftsmanship in handscraping techniques
- Field expandable 2-station APC with high speed 4th Axis rotary table and rotary scale. Integral drive motor driven with rapids 45,000deg/min (125min<sup>-1</sup>)
- Ultra-high-speed rapid/cutting feeds, 60m/min (2,362ipm) on solid box ways
- Induction Hardened solid box guideways
- Powerful 15,000min<sup>-1</sup>, 30HP Direct Drive, Dual Contact Spindle. 20,000min<sup>-1</sup> HSK spindle is an available option.
- Ballscrew cooling and fine resolution linear scale feedback in X, Y, Z axes
- Standard hinge belt style conveyor combined with dual internal chip augers = High efficiency chip evacuation

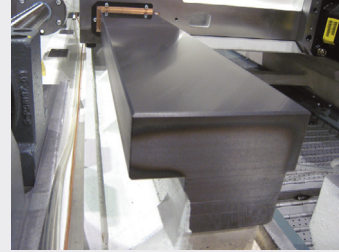

*In-house induction hardened solid box ways provide the mass, stability and damping capacity necessary to offer heavier cutting ability, superb surface finishes and longer tool life.*

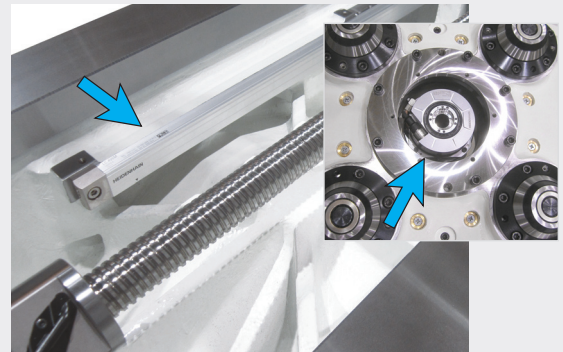

*Standard linear (X,Y,Z) and rotary scale (B) feedback offer long term, highest in-class accuracy while minimizing displacement even at outer edges of table limits.*



**Quick Pull Down Menu**

## Arumatik® Mi

### Pioneering Icon CNC Operation

- 67 Million pulse encoder technology with up to 8,192 block look-ahead processing speeds
- Software upgrades throughout the life of the control
- Completely customizable and expandable user experience
- Video Guidance and visual programming screens
- Anywhere-Remote® E-Mail status updates



**Customizable Icon Screen.** Advanced touch screen capabilities with user customized main menu touch screen and a variety of visual programming screens and functions that offer the operator faster and easier methods of part set-up and processing.

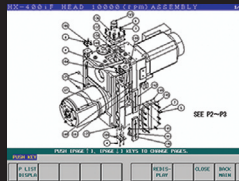

**Maintenance Support Function.** Kitamura's Maintenance Support Function offers operator convenience in displaying methods of machining maintenance, repair and parts support on the NC Screen.

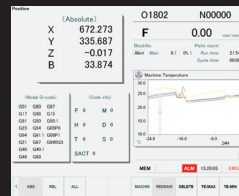

Our high efficiency **Intelligent Advanced Control System (IAC)** consists of a series of strategically located sensors and machine efficiency monitors that work to keep component growth due to machining heat build-up to less than ±5 microns (±0.0002").

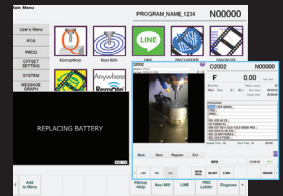

**Video Guidance.** Useful functions visually walk the user through methods of battery replacement, alarm release, APC recovery, PMC ladder and alarm release / guidance making it easier to monitor machine performance and uptime.

**Positioning Accuracy** +/-0.002mm (+/-0.000079") / Full Stroke

**Repeatability** +/-0.001mm (+/-0.000039")

**World renowned JAPANESE**



# mm mid to large size horizontal machining technology

## for your most challenging workpieces

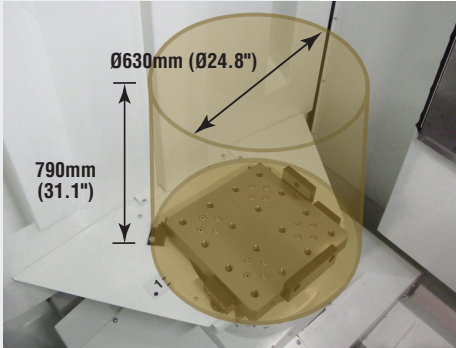

### Generous Work Envelope

Ø630mm (Ø24.8") x 790mm (31.1") H. Standard 2-APC system and full 4th axis offer smart fixturing and work holding options. An additional 5th axis can be added to BOTH pallets in the field for ultimate flexibility and less handling of your more complex parts.

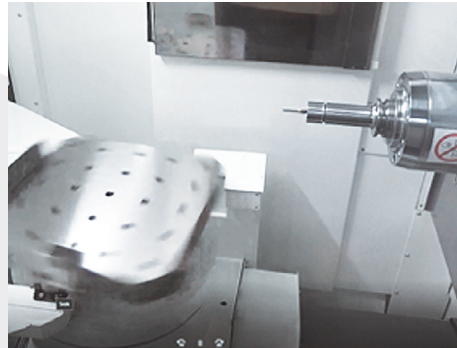

### High Speed B-Axis - Integral Drive Motor Driven 45,000deg/min (125min<sup>-1</sup>) Rotation.

- Positioning Accuracy ±2 arc sec
- High resolution built-in Heidenhain rotary encoder
- Zero backlash
- Dramatically faster indexing time reduces out of cut time and increases the amount of material removed in milling applications. Turning is possible with "Fastest in class"



### Exclusive 50-tool fixed pot ATC.

In-the-field tool capacity expansion up to 200 tools. Ultra-fast 1.3 sec. T-T change time optimizes machine performance.

## Available Options



Non-Contact Tool Probe

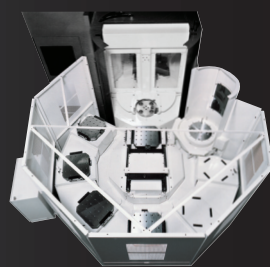

Field Expandable Multi-Pallet Systems

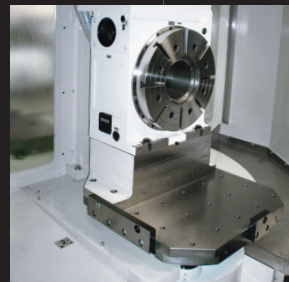

Field Retrofittable 5th Axis Rotary Tables (available on both pallets)



Up to 1000psi Coolant Thru the Spindle Available

Machine Model	Operational Status	Program	Running Time	Remaining Time
Prisma 3000	Running	Program 12345	00:05	00:15
Prisma 3000	Running	Program 12345	00:10	00:20
Prisma 3000	Running	Program 12345	00:15	00:25
Prisma 3000	Running	Program 12345	00:20	00:30
Prisma 3000	Running	Program 12345	00:25	00:35
Prisma 3000	Running	Program 12345	00:30	00:40
Prisma 3000	Running	Program 12345	00:35	00:45
Prisma 3000	Running	Program 12345	00:40	00:50
Prisma 3000	Running	Program 12345	00:45	00:55
Prisma 3000	Running	Program 12345	00:50	01:00

- Machine Monitoring Software Suite
- MTConnect Ready Adaptor



Double Decker Style Chip Conveyor

# SPECIFICATIONS Mycenter-HX400iG/500

## Table

Table Size	400 x 400mm (15.7" x 15.7")
Table Indexing	0.001 Degree (4th Axis)
Tapped Hole (Size xQty.)	M16 x 2.0 x 25
Max. Table Load	350/*400kg (770/*880lbs.) * With Limitations
Max. Workpiece Dia.	Ø630mm (Ø24.8")
Max. Workpiece Height	790mm (31.1")

## Travels

X-Axis Travel	610mm (24.0")
Y-Axis Travel	610mm (24.0")
Z-Axis Travel	610mm (24.0")
B-Axis Travel	0 to 360 Degrees Full 4th Axis
Table Surf. to Spindle Center	40 ~ 650mm (1.6" to 25.6")
Table Center to Spindle Nose	100 ~ 710mm (3.9" to 27.9")

## Spindle

Spindle Taper	#40 NST (HSK-A63 Opt.)
Spindle Speed	40 ~ 15,000min <sup>-1</sup> (20,000min <sup>-1</sup> Opt.)
Drive Method	Direct Drive
Maximum Spindle Torque	95.5 N·m (70.4 ft·lbs)
Spindle Motor	22kW (30HP AC/ 5 min) 15kW (20HP AC/10 min) 11kW (15HP AC/30 min) 7.5kW (10HP AC/Cont.)

## Feed

Rapid Feed X,Y,Z	60m/min (2,362ipm)
Cutting Feed Rate X,Y,Z	60m/min (2,362ipm)
Rapid Feed (B-Axis)	45,000 deg/min (125min <sup>-1</sup> )

## APC

Number of Pallets	2
APC Change Time	8.5 seconds

## ATC

Tool Storage Capacity	50 Tools (Opt. 62, 100, 150, 200)
Tool Selection Method	Random bi-directional, Fixed Pot
Tool Holder Style	CT (BT) 40 (HSK-A63 Opt.)
Max. Tool Dia.	Ø95mm (Ø3.7") / Ø150mm (Ø5.9")
Max. Tool Length	370mm (14.6")
Max. Tool Weight	10kg (22 lbs.)
Tool to Tool	1.3 seconds
Chip to Chip	2.5 seconds, min.

## Utilities

Power Requirement	50KVA, 200v AC, 3 Phase
Air Requirement	0.5 MPa, 350L/min (90psi, 13cfm)
For 20,000 min <sup>-1</sup> Spindle	0.5 MPa, 410L/min (90psi, 15cfm)

## Machine Dimensions

Required Space (W x D)	3,068 x 4,065mm (120.8" x 160.0")
Machine Height	2,739mm (107.8")
Machine Net Weight	9,800kg (21,560 lbs.)

## Control

**Arumatik-Mi**

Specifications subject to change without notice.

# FLOOR PLANS

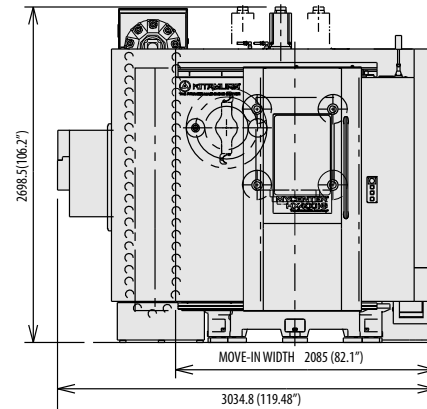

## Side View

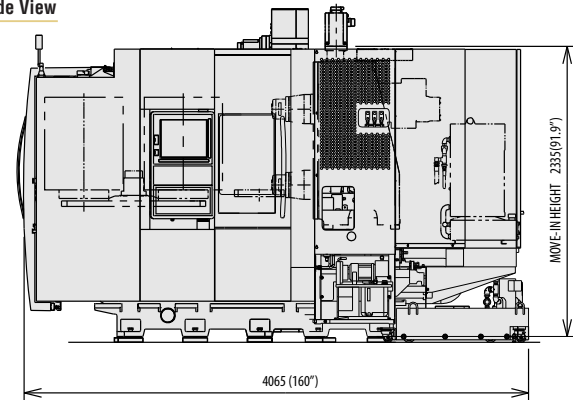

## Layout View

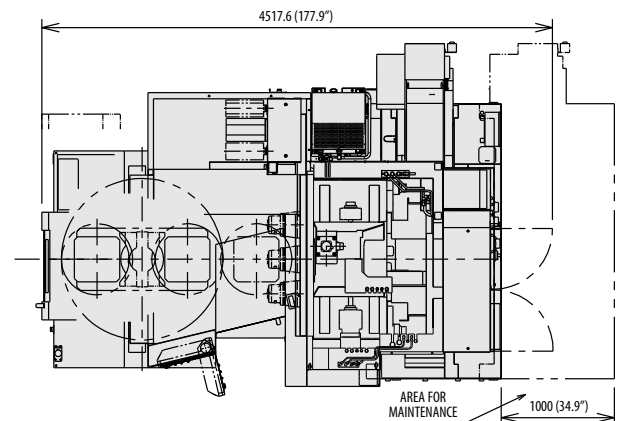

### Kitamura Machinery of U.S.A., Inc.

451 Kingston Court, Mt. Prospect, IL 60056 +1 847 520 7755  
kitamura-machinery.com info@kitamura-machinery.com

### Kitamura Machinery Co., Ltd.

1870-Toide, Takaoka-City, Toyama Pref., Japan +81 766 63 1100  
kitamura-machinery.co.jp mycenter@kitamura-machinery.co.jp

### Kitamura Machinery GmbH (Europe)

Wahlerstrasse 39, 40472 Dusseldorf, Germany +49 211 657 9010  
kitamura-machinery.eu sales@kitamura-machinery.eu