

SPECIFICATIONS Mycenter-HX250iG

Table	
Table Size	254 x 254mm (10.0" x 10.0")
Table Indexing	0.001 Degree (4th Axis)
Tapped Hole (Size x Qty.)	M12 x 1.75 x 8
Max. Table Load	100kg (220 lbs.)
Max. Workpiece Dia.	Ø350mm (Ø13.8")
Max. Workpiece Height	400mm (15.7")
Travels	
X-Axis Travel	305mm (12.0")
Y-Axis Travel	305mm (12.0")
Z-Axis Travel	330mm (13.0")
B-Axis Travel	0 to 360 Degrees Full 4th Axis
Table Surf. to Spindle Center	60 to 365mm (2.4" to 14.4")
Table Center to Spindle Nose	60 to 390mm (2.4" to 15.4")
Spindle	
Spindle Taper	#30 NST (HSK-E40 Option / 30k)
Spindle Speed	150 ~ 15,000min ⁻¹ (30,000min ⁻¹ Opt.)
Drive Method	Direct Drive
Maximum Spindle Torque	70.0 N•m (51.6 ft•lbs)
Spindle Motor	11kW (15HP AC/30 min) 7.5kW (10HP AC/Cont.)
Feed	
Rapid Feed X,Y,Z	60m/min (2,362ipm)
Cutting Feed Rate X,Y,Z	60m/min (2,362ipm)
Rapid Feed (B-Axis)	108,000 deg/min (300 min ⁻¹)
APC	
Number of Pallets	2 (Opt. 10-Station Pallet Pool)
APC Change Time	7.9 seconds
ATC	
Tool Storage Capacity	40 Tools (Opt. 52, 102)
Tool Selection Method	Random Bi-Directional, Fixed Pot
Tool Holder Style	BT 30 (HSK-E40 Opt.)
Max. Tool Dia.	Ø50mm (Ø2.0") / Ø75mm (Ø3.0")
Max. Tool Length	200mm (7.9")
Max. Tool Weight	3kg (6.6 lbs.)
Tool to Tool	0.9 seconds
Chip to Chip	2.8 seconds, min.
Utilities	
Power Requirement	30KVA, 200v AC, 3 Phase
Air Requirement	0.5 MPa, 150L/min (90psi, 6cfm)
Machine Dimensions	
Required Space (W x D)	2,330 x 2,948mm (91.7" x 116.1")
Machine Height	2,470mm (97.2")
Machine Net Weight	5,210kg (11,462 lbs.)
Control	Arumatik-Mi

Specifications subject to change without notice.

FLOOR PLANS

Front View

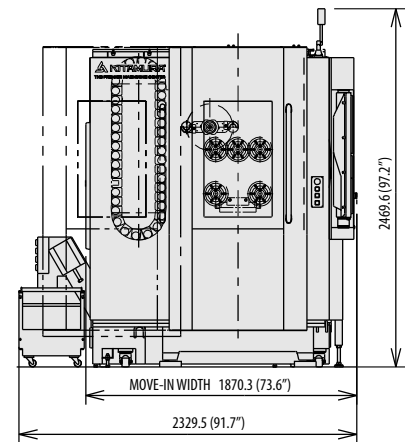

Side View

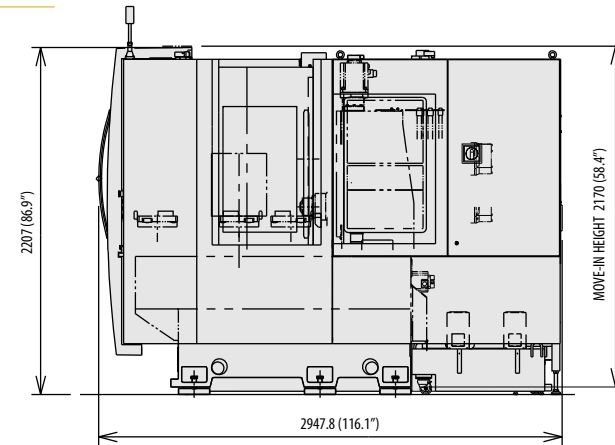

Layout View

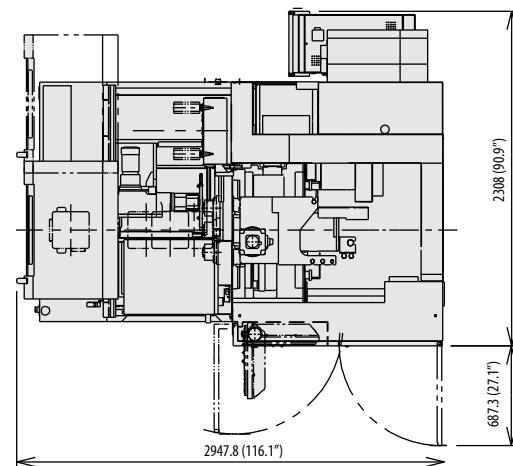

Kitamura Machinery of U.S.A., Inc.
451 Kingston Court, Mt. Prospect, IL 60056 +1 847 520 7755
kitamura-machinery.com info@kitamura-machinery.com

Kitamura Machinery Co., Ltd.
1870-Toide, Takaoka-City, Toyama Pref., Japan +81 766 63 1100
kitamura-machinery.co.jp mycenter@kitamura-machinery.co.jp

Kitamura Machinery GmbH (Europe)
Wahlerstrasse 39, 40472 Dusseldorf, Germany +49 211 657 9010
kitamura-machinery.eusales@kitamura-machinery.eu

PRINTED IN USA 06/22 REV 3



MYCENTER®

HX250iG



HORIZONTAL MACHINING CENTER

SIMPLIFY THE COMPLICATED

HX250iG The machine for high speed, high productivity intricate machining of small components

Power & precision in an ultra-compact footprint

- Rigid 4,500kg (9,900Lbs) Meehanite cast construction manufactured in Japan with craftsmanship in handscraping techniques
- Space-saving, ultra compact 2.33 x 2.95m (7.7' x 9.7') footprint
- 2-station APC with high speed 4th Axis rotary table with rotary scale. Integral drive motor driven with rapids of 108,000deg/min (300min⁻¹)
- Ultra-high-speed rapid/cutting feeds, 60m/min (2,362ipm)
- Ultra-high speed tool change, T-T 0.9 Seconds
- High performance THK double roller linear guideway system
- Powerful 15,000min⁻¹, 15HP Direct Drive, Dual Contact Spindle. 30,000min⁻¹ HSK spindle is an available option
- Standard scraper type chip conveyor with rolling filtration system

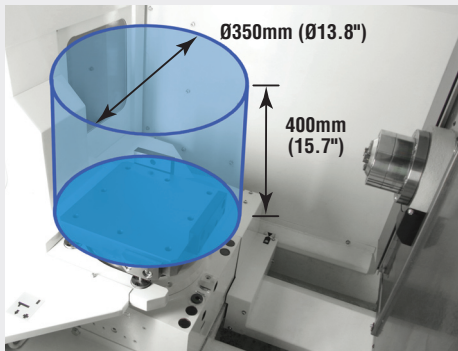

All mating surfaces are hand scraped to assure an absolutely perfect fit. No need for geometry compensation to adjust for squareness, parallelism and perpendicularity. High performance THK double roller linear guideways offer long life expectancy while holding accuracies. Smooth and quiet operation.

Generous Work Envelope
 Ø350mm (Ø13.8") x 400mm (15.7") H.
 Standard 2-APC system and full 4th axis offer smart fixturing and work holding options. An additional 5th axis can be added to BOTH pallets in the field for ultimate flexibility and less handling of your more complex parts.

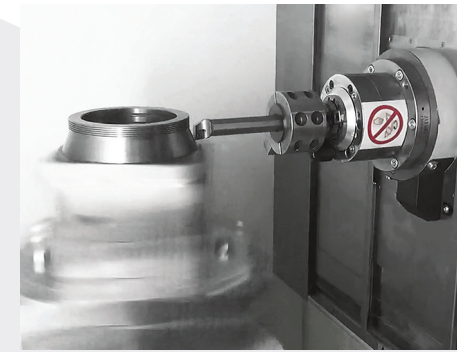

High Speed B-Axis - Integral Drive Motor Driven 108,000deg./min (300min⁻¹) Rotation.

- Positioning Accuracy ± 2 arc sec
- High resolution built-in Heidenhain rotary encoder
- Zero backlash
- Dramatically faster indexing time reduces out of cut time and increases the amount of material removed in milling applications. Turning is possible with "Fastest in class" rapid feeds.

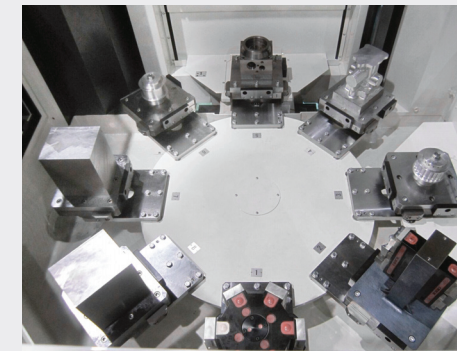

Now Available - Field installable 10-Station APC System. Fits within a compact 4,117mm (163") deep x 2,995mm (118") wide footprint.



Quick Pull Down Menu

Arumatik-Mi Pioneering Icon CNC Operation

- 67 Million pulse encoder technology with up to 8,192 block look-ahead processing speeds
- Software upgrades throughout the life of the control
- Completely customizable and expandable user experience
- Video Guidance and visual programming screens
- Anywhere-RemOTE E-Mail status updates



Customizable Icon Screen. Advanced touch screen capabilities with user customized main menu touch screen and a variety of visual programming screens and functions that offer the operator faster and easier methods of part set-up and processing.

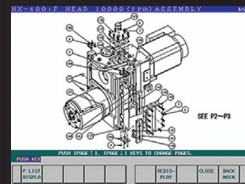

Maintenance Support Function. Kitamura's Maintenance Support Function offers operator convenience in displaying methods of machining maintenance, repair and parts support on the NC Screen.

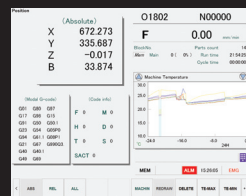

Our high efficiency **Intelligent Advanced Control System (IAC)** consists of a series of strategically located sensors and machine efficiency monitors that work to keep component growth due to machining heat build-up to less than ± 5 microns (± 0.0002 ").

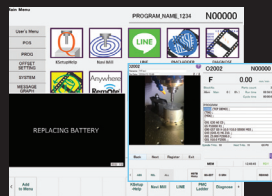

Video Guidance. Useful functions visually walk the user through methods of battery replacement, alarm release, APC recovery, PMC ladder and alarm release / guidance making it easier to monitor machine performance and uptime.

Available Options

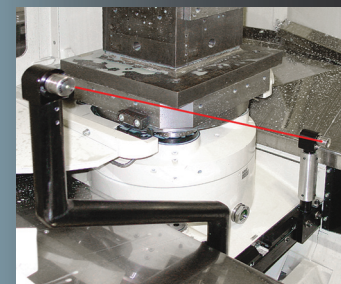

Spindle and Tool Probes

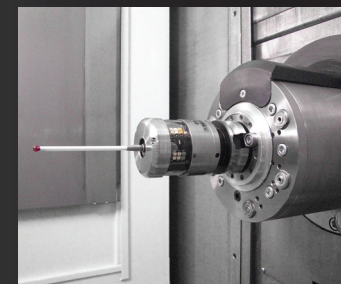

Field Retrofittable 5th Axis Rotary Tables (available on both pallets)

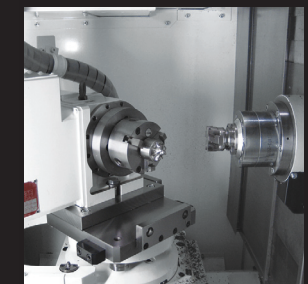

Up to 1000psi Coolant Thru the Spindle Available



- Machine Monitoring Software Suite
- MTConnect Ready Adaptor



Smart Fixturing and Workholding Options

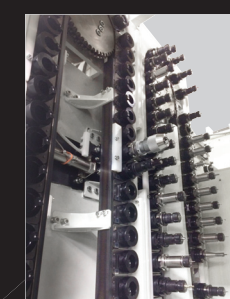

Field Expandable 102 Tool ATC Magazine

Positioning Accuracy ± 0.002 mm (± 0.000079 ") / Full Stroke Repeatability ± 0.001 mm (± 0.000039 ")

World renowned JAPANESE

design, engineering and manufacture since 1933