



# YANGZHOU METALFORMING MACHINE TOOL CO.,LTD.

扬州锻压机床有限公司

**SINCE 1958**



微信公众号



抖音官方号

## 扬州锻压机床有限公司

YANGZHOU METALFORMING MACHINE TOOL CO.,LTD.

地址: 江苏省扬州市高新技术产业开发区华钢路1号

Add: No.1, Huagang Rd., Yangzhou Hi-tech Industry Development Zone, Jiangsu, China

邮编/PC: 225128

电话/Tel: 0514-8784 9888 8784 9988

传真/Fax: 0514-8784 9136

邮箱/E-mail: sales@yadon.com.cn

网址/Http: www.duanya.com.cn

开户行: 招商银行股份有限公司扬州邗江支行

账号: 5149 0206 1210 903







# BRIEF INTRODUCTION

## 企业简介



### TO BE A FRONTRUNNER OF THE GLOBAL MIDDLE-END PRESS MARKET

## 成为全球中高端压力机市场的领跑者

扬州锻压机床有限公司（扬锻Yadon）始创于1958年，系德国Schuler中国子公司，专业从事成形设备的研发、制造和销售，涵盖机械压力机、高速冲床、热锻、粉末成形机、机床再制造等；为汽车、家电、五金、电机、电子、轨道交通、航空航天等众多行业提供丰富的冲压自动化解决方案。

公司主导产品有开式、闭式压力机，单点、双点、四点压力机，重型压力机，多连杆压力机，肘杆压力机，伺服压力机，级进模和多工位压力机等；翅片高速冲床，电机铁芯高速冲床，罐盖高速冲床，链条等行业专用高速冲；热模锻、电动螺旋、切边精整压力机等锻造设备；粉末成形机、粉末整形机等。

公司拥有省级企业技术中心，近年来承担了十余项国家级重大科技项目，主持、参与制定多项行业标准。多次荣获中国机床工具行业30强企业、中国锻压行业“优秀冲压设备供应商”和“优秀锻造设备供应商”、中国模具工业行业“优秀模具成形设备供应商”等。

在舒勒集团技术、管理和全球化支持下，扬锻YADON致力于成为“全球中高端压力机市场的领跑者”，积极致力于中国锻压行业技术的进步，为客户提供一流的产品和周到的服务。

Founded in 1958, Yangzhou Metalforming Machine Tool Co., Ltd (YADON) has now become a subsidiary of Schuler Group. We have been specializing in R&D, manufacturing and selling of forming machines, covering mechanical press, high-speed press, die forging presses, powder forming machines, fine blanking machines, press remanufacturing and etc. Besides, YADON is in the lead of providing automatic stamping solutions, including transfer line, multi-station press line, and multi-machine line. Over the past decades, YADON has obtained the core competitiveness of high efficiency, stability, precision and low-cost production by satisfying customers strict requirements with high-quality products and service.

Our company's main products are C-type Frame press, Straight side press, Single-point press, Double-point press, Four-point press, Knuckle Precision press, Multi-link press, Heavy-duty press, Servo press, Progressive and transfer press lines, and various types of mechanical press machines. We also produce different kinds of High-speed presses, including fin press line, rotor and stator stamping line, high-speed precision press for can lid and other electronic components. In addition, we produce forging press like hot/warm forging press, electric screw press, sizing/trimming press, and powder metallurgy forming equipment includes powder compacting machine, powder sizing machine and etc.

YADON is a key national high-tech enterprise and the backbone of the National Torch Plan Hanjiang CNC Metal Sheet Processing Equipment Industrial Zone. On the strength of the provincial enterprise technology center and national post-doctoral research workstation, YADON has undertaken more than 10 national major scientific and technological projects, acquired many national invention patents and hundreds of utility model patents in recent years. Among other things, we have presided over or involved in development of a number of industry standards.

For now, the company has more than 940 employees, 70% of whom have college degree or above, 26 employees with senior titles, and 60 employees with intermediate titles.

YADON has more than 80 marketing outlets both domestically and abroad. Such a global marketing and service network ensures zero-time difference and non-stop pre-sales to after-sales service.

With Schuler's support on technology, management and globalization, YADON, taking the vision as "To be a front-runner of the global middle-end press market", and carrying forward the entrepreneurial spirit of "pragmatism, inclusiveness, innovation and efficiency", has been dedicating in improving China's forming/forging industry, and providing customers with top-ranking products as well as attentive service.



# YADON HISTORY 发展历程

<p>1958年 公司创立 Company founded</p>	<p>1978年 “邗江锻压机床厂” 16T、40T 压力机获部、省优质产品称号 Won as ministerial qualified products</p>	<p>1987年 “扬州锻压机床厂” 1989年引进意大利技术生产JL系列高性能压力机 Start produce presses with imported Italian technology</p>	<p>1996年 “江苏金方圆集团扬州锻压机床有限公司” 1997年同行中率先通过ISO9001质量体系认证 Obtained ISO 9001 certificate firstly in press making industry</p> <p>1998年YKC空调翅片高速精密冲压生产线 Start produce YKC aluminium fin press line</p>	<p>2005年 “扬州锻压机床集团有限公司” 2006年MP-1600多工位锻造生产线 Start produce MP hot forging machines</p>	<p>2011年 “扬州锻压机床股份有限公司” 技术中心被评为省级“优秀企业技术中心” 2011年 总部迁至邗江经济开发区华钢路1号 Head-quarter moved to huagang road in 2011</p>	<p>2016年 与压力机设备的技术先驱和全球市场领航者德国舒勒集团合资 In 2016, The press manufacturer Schuler AG has acquired a majority shareholding in Yadon, this marks that Yadon became a Joint venture with Schuler.</p>	<p>2019年 “扬州锻压机床有限公司” 6900m²新重型装配车间 New assembly workshop of heavy press</p>
---	--	--	---	--	---	---	--

<p>1963年 压力机事业起步 Start press making from 1963s</p>	<p>1975年 被原“机械部”批准为定点生产机械压力机专业厂家 Appointde as one of press makers by the ministry of machinery</p>	<p>1984年 引进日本技术生产JH系列高性能压力机 Start produce JH21 series presses with imported Japanese technology</p> <p>被省政府表彰为“出口创外汇先进企业”、被原外经贸部批准为出口企业 Awarded as “advanced foreign exchange earning entorprise” by Jiangsu province government. Appointed as export enterpriseby previous foreign trading ministry.</p>	<p>1990年代初国内第一台数控转塔冲 Produced 1st set of CNC turret punching machine in China</p> <p>1993年开式空调翅片冲压生产线 Start produce c-type Fin line</p> <p>1995年开式双点压力机 Start c-type double-crank press</p> <p>1991~1995年 国家火炬计划企业 Awarded as national torch enterprise and provincial 江苏省高新技术企业 Hi-tech enterprise 1 个国家“火炬项目” 1 National torch project 1 个国家“星火项目” 1 National spark project</p>	<p>2000年闭式双点压力机 Start produce double-crank press machines</p> <p>2003年被认定为国家火炬计划重点高新技术企业 2004年总部迁至邗江经济开发区吉安路 National major Hi-tech enterprises, moved to Hanjiang economic development zone in 2004</p>	<p>2007年 技术中心被认定为“省级企业技术中心” Awarded as china famous brand and provincial technical center</p> <p>2009年 承担国家科技重大专项：高速精密数控冲床，10000KN精冲机 National scientch major project: high-speed precision CNC presses fine blanking presses</p> <p>2010年 公司商标由“D”变更为“YADON” Start new logo</p>	<p>2013年 承担国家科技重大专项： J76-750数控重型高速精密压力机 National scientch major project: J76-750 heavy high-speed press 江苏省创新团队 Jiangsu province innovation team</p> <p>800T粉末成形压力机（国内首台套） Powder compacting press(the 1st one made in china)</p>	<p>2017年 YT4L-2500多工位压力机 YT4L-2500 Transfer Press</p> <p>YSH-400三点/四点高速精密冲压线 YSH-400 Straight Side High-speed Three/Four-point Press Line</p>	<p>2022年 重型压力机二期 Heavy Press Phase II Plant Construction</p>
--	--	---	---	--	--	---	---	--

SINCE 1958





### PLM全三维在线设计工作平台

根据需要，选择实体化得模型，结合完整的结构树，实现全三维在线设计

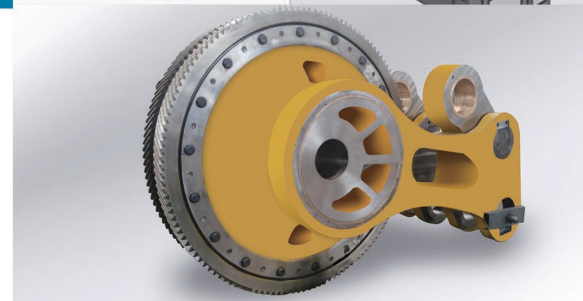
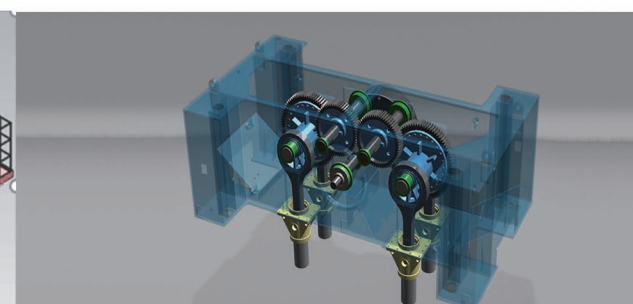
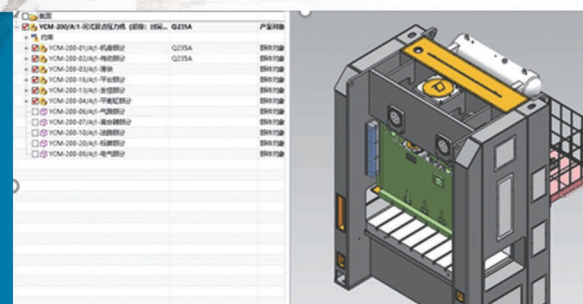
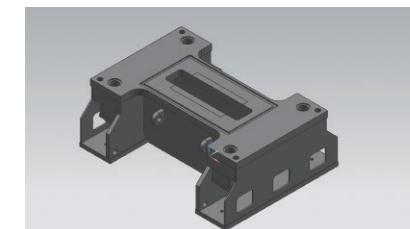
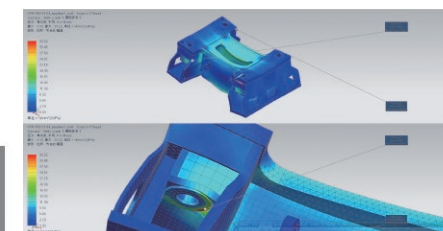
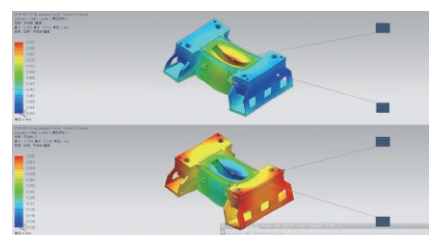

## RESEARCH DESIGN 研发

SIEMENS Teamcenter PLM研发管理平台，NX三维设计、NASTRAN有限元分析、EPLAN电气设计等。研发团队100余人，高级职称以上34余人，国家及省级专家6人。

公司主持或参与制定国家和行业标准9项，承担国家科技重大专项4项、国家创新基金2项、省科技成果转化2项、省科技支撑计划4项、国际科技合作5项。拥有国家发明专利15项、实用新型专利160余项、外观专利4项、软件著作权8项等。

德国Schuler技术支持：机床可靠性提升、多连杆技术、多工位压力机、重型压力机、伺服压力机、锻造等。

Siemens Teamcenter PLM R & D management platform, NX 3D design, NASTRAN finite element analysis, EPLAN electrical design, etc. There are more than 100 R & D team members, more than 34 with senior titles and 6 national and provincial experts.

The company presides over or participates in the formulation of 9 national and industrial standards, undertakes 4 major national science and technology projects, 2 national innovation funds, 2 provincial science and technology achievements transformation, 4 provincial science and technology support plans, and 5 international science and technology cooperation. It has 15 national invention patents, more than 160 utility model patents, 4 appearance patents and 8 software copyrights.

German Schuler technical support: machine tool reliability improvement, multi link technology, multi station press, heavy press, servo press, hot forging, etc.

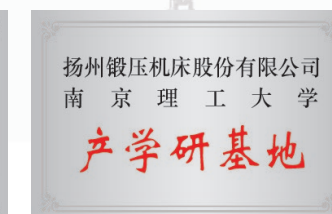
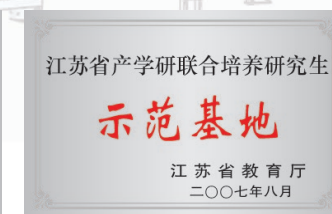
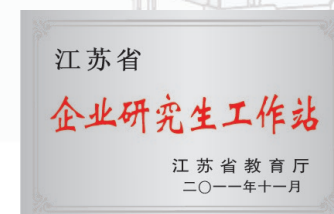
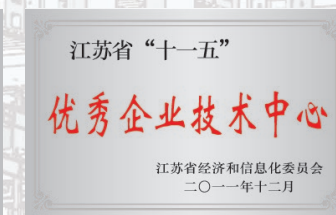



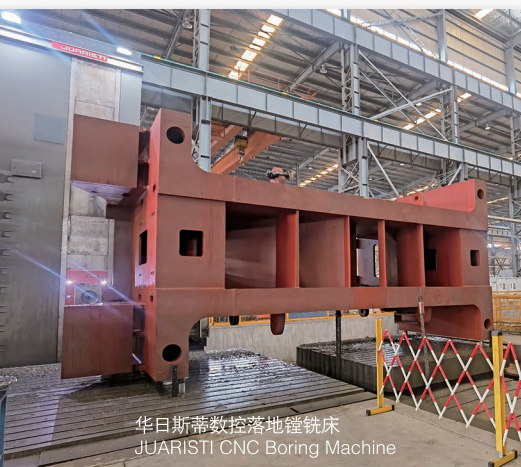

华日斯蒂数控落地镗铣床  
JUARISTI CNC Boring Machine

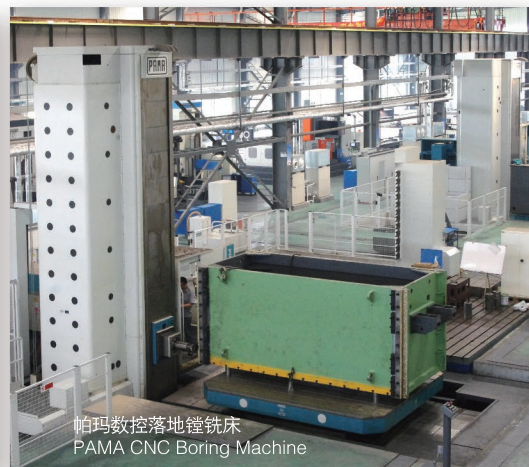

帕玛数控落地镗铣床  
PAMA CNC Boring Machine



三菱数控龙门加工中心  
MITSUBISHI CNC Milling Machine

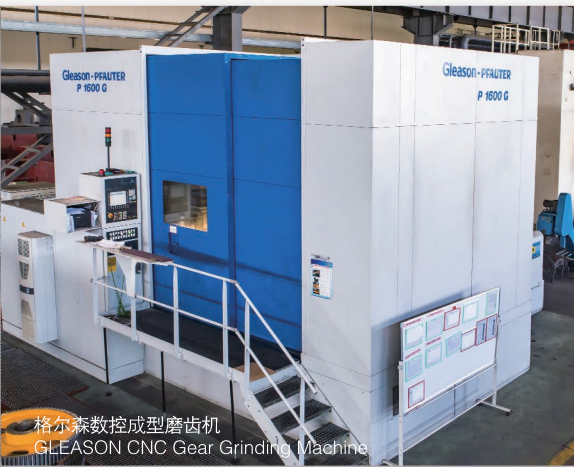

格尔蒙数控成型磨齿机  
GLEASON CNC Gear Grinding Machine



数控人字齿复合铣齿机  
CNC herringbone compound gear milling machine



数控双柱立式车床  
CNC double column vertical lathe

## PROCESSING CONTROL CENTER 加工与检验

公司拥有业界领先的加工和检测设备，65年专业制造经验和丰富工艺积累，舒勒技术标准的现代化生产和品质保障体系。

The company has industry-leading processing and testing equipment, more than 65 years of professional manufacturing experience and rich accumulation of technology, in line with the Schuler technical standards of modern production and quality assurance system.



莱卡激光跟踪仪  
LEICA Laser Measuring Machine



海克斯康 6轴绝对臂  
HEXAGON 6-axis Absolute Arm



海克斯康龙门三坐标  
HEXAGON 3D Measuring Machine

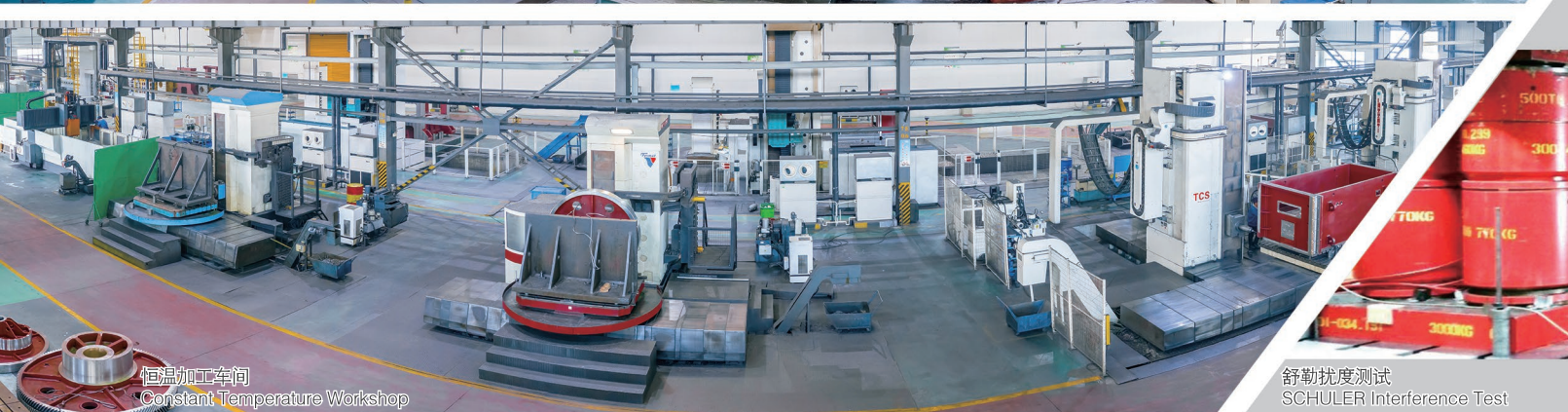

恒温加工车间  
Constant Temperature Workshop



舒勒扰度测试  
SCHULER Interference Test



斯派克光谱仪  
SPECTRO Spectrometer



退火炉  
Annealing Furnace



抛丸机  
Shot Blasting Machine





**SALES NETWORK**  
**营销&服务网络**

遍及全球的营销服务网络，为客户提供零时差、一体化的售前、售中、售后服务。  
Worldwide marketing services network, provide the zero time difference, for the customer pre-sales and post-sales customer service integration.

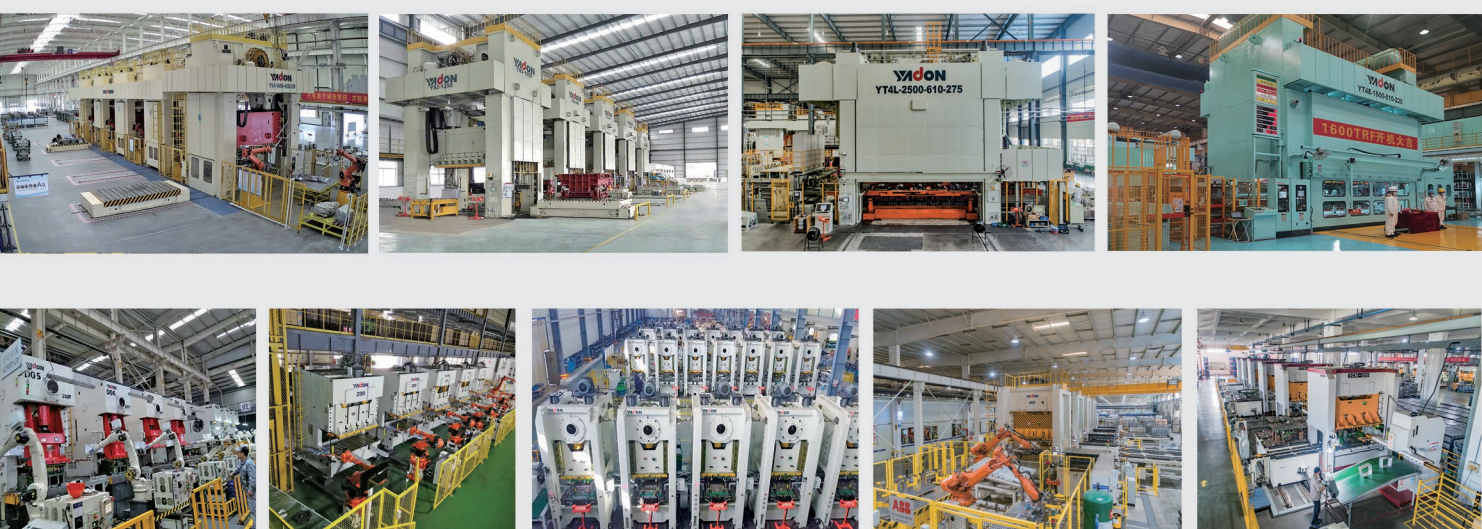



# 目录 CONTENTS

## 机械压力机 Mechanical Presses



YS2/YS2A 闭式双点压力机 YS2/YS2A Straight Side Two-point Press	13
YS4/YS4L 闭式四点(多连杆)压力机 YS4/YS4L H-type Frame Four-point (Link Drive) Press	17
YP2/YP2E/YP4E 闭式双点/四点连续模压力机 YP2/YP2E/YP4E Straight Side Two/Four-point Press	19
YT2E/YT4E/YT4L 多工位压力机 YT2E/YT4E/YT4L Transfer Press	21
YB4E 闭式四点落料压力机 YB4E Four-point Blanking Press	23
JH31 闭式单点压力机 JH31 Straight Side One-point Press	25
JF31 闭式单点压力机 JF31 Straight Side One-point Press	26
YPM 闭式双点连续模压力机 YPM Straight Side Two-point Press	27
YM 连杆式双点精密压力机 YM Link Drive Two-point Precision Press	28
JH21 开式固定台高性能压力机 JH21 C-type Frame Fixed Table Press	29
JK21 开式固定台高性能压力机 JK21 C-type Frame Fixed Table Press	31
JL21 开式固定台高性能压力机 JL21 C-type Frame Fixed Table Press	33
J25 开式双点压力机 J25 C-type Frame Double-crank Press	35
YS1/YS1Z 闭式单点压力机 YS1/YS1Z Straight Side Single Crank Press	37
JB36 闭式双点压力机 JB36 Straight Side Double Crank Press	39
YCM 闭式双点压力机 YCM Straight Side Double Crank Press	41
JY21 半闭式固定台高性能压力机 JY21 Semi-closed Type Fixed Table Press	43
J24 开式快速回程压力机 J24 C-type Frame Link Drive Press	45
JB36L 闭式双点快速回程压力机 JB36L Straight Double-crank Frame Link Drive Press	46

## 高速压力机 High Speed Presses



JL21G 开式高速压力机 JL21G C-type Frame High-speed Press	55
YCH/Y2H/YG1 罐盖高速精密压力机 YCH/Y2H/YG1 High-speed Precision Press	56
J31K 闭式快速强力压力机 J31K Straight Side High-speed Powerful Press	57
JL21 空调翅片高速冲压自动生产线 JL21 C-type Fin Press Line	58
YKC 空调翅片高速冲压自动生产线 YKC H-type Fin Press Line	59

## 精冲机 Fine Blanking Machines



YKP 肘杆式精压机 YKP Knuckle Precision Press	61
YKL1 快速回程肘杆精密压力机 YKL1 Link Drive Knuckle Precision Press	62
YFB 精冲机 YFB Fine Blanking Press	63

## 热锻 Forging Machines

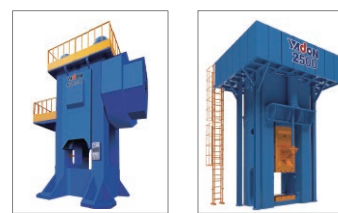

MP 高速精密热模锻压力机 MP Hot Forging Press	65
MGP 高速精密热模锻压力机 MGP Series Hot Forging Press	67
YHF 热模锻压力机 YHF Series Hot Forging Press	69
J58 伺服直驱电动螺旋压力机 J58 Servo Direct Drive Electric Screw Press	71
YHQ2 双点精密切边整形压力机 YHQ2 Two Points Precision Trimming Press	73

## 高速压力机 High Speed Presses



YSH 闭式三点/四点高速精密冲压线 YSH Straight Side High-speed Three/Four-point Press Line	47
J76 闭式双点高速精密冲压线 J76 Straight Side High-speed Two-point Precision Press Line	49
YPH 大电机级进模冲压线 YPH Motor Lamination Production Line(Big-size Motor)	51
J31G 闭式单点高速压力机冲压线 J31G Straight Side High-speed One-point Press Line	53

## 其他冲压设备 Others



JX21 橡胶瓶塞除边机 JX21 Brim Cutting Machine for Rubber Bottle Stopper	74
---	----



# YS2/YS2A 闭式双点压力机

## Straight Side Two-point Press



### 主要功能和特点 Main Structure Features

- ◆ 适合单工程模冲压，或多机串联自动化冲压线；
  - ◆ 横梁、滑块、立柱、底座分体钢板焊接，CAE分析获得高刚性机身；
  - ◆ 偏心齿轮带导柱导套结构，双点传动；
  - ◆ 高精度全程八面导向；
  - ◆ 气动离合制动器，摩擦块寿命长；
  - ◆ 高灵敏度液压过载保护；
  - ◆ 稀油自动循环润滑；
  - ◆ 安全装置齐全，配置光电保护、维修平台、顶部护栏、安全栓等；
  - ◆ 选配：自动化设备、双移动台、气垫（液压垫）、吨位仪、夹模器、减震垫、安全门、废料槽、湿式离合器、滑块锁紧等装置。
- ◆ Apply to single-station die or multi-press automatic stamping line.
  - ◆ Tie-rod structure, the Crossbeam, slide, columns and base are welded steel, high rigidity frame realized by CAE analysis.
  - ◆ Double-point transmission structure with eccentric gear, guide rod and bush.
  - ◆ Full length 8-side long guide rail with high precision.
  - ◆ Pneumatic clutch-brake with long-life friction block.
  - ◆ High sensitive HOLP.
  - ◆ Automatic oil cycle lubrication system.
  - ◆ Full safety device equipped with photoelectric protection, maintenance platform, safety fence, safety block etc.
  - ◆ Optional: Automation equipments, additional moving bolsters, air cushion (Hydraulic cushion), tonnage monitor, die clamps, anti-vibration pads, safety door, scrap chute, wet clutch, slide lock device etc.

### 技术参数 Specifications

技术参数 Technical Data		型号 Model	YS2A-250	YS2A-315	YS2A-400	YS2-400				YS2-500	YS2-500				YS2-630						
名称 Items																					
公称力 Nominal Pressure	KN		2500	3150	4000	4000	4000	4000	4000	5000		5000	5000	5000	5000	6300	6300	6300	6300	6300	
公称力行程 Nominal Pressure Stroke	mm		13	13	13	13	13	13	13	13		13	13	13	13	13	13	13	13	13	
滑块行程 Stroke of Slide	mm		400	400	400	400	500	600	700	500		600	600	700	800	500	500	600	600	600	
行程次数 Stroke	S.P.M		16~25	16~25	16~25	10~20	10~20	10~20	10~20	10~20		10~20	10~20	10~20	10~20	10~20	10~20	10~20	10~20	10~20	
最大装模高度 Max. Die Set Height	mm		800	800	900	1000	1000	1000	1200	1000		1000	1200	1200	1200	1000	1000	1200	1200	1200	
装模高度调节量 Die Height Adjustment	mm		350	350	400	400	400	400	500	400		400	500	500	500	400	400	500	500	500	
工作台板 Bolster	台板尺寸（左右X前后） Size of Bolster	mm	2770X1250	2770X1250	2800X1600	2800X1600	2800X1600	3200X1600	3600X1800	3200X1600		3200X1600	3600X1800	3600X1800	3600X1800	3200X1600	3600X1800	3200X1600	3600X1800	4000X1800	
	形式 Direction of Moving Bolster		固定台 Fix	固定台 Fix	固定台 Fix	前移/侧移 Front/Side Moving	前移/侧移 Front/Side Moving	前移/侧移 Front/Side Moving	前移/侧移 Front/Side Moving	前移/侧移 Front/Side Moving		前移/侧移 Front/Side Moving	前移/侧移 Front/Side Moving	前移/侧移 Front/Side Moving	前移/侧移 Front/Side Moving	前移/侧移 Front/Side Moving	前移/侧移 Front/Side Moving	前移/侧移 Front/Side Moving	前移/侧移 Front/Side Moving	前移/侧移 Front/Side Moving	
	工作面距离地面高度 Height From Floor to Bolster Surface	mm	800	800	800	650	650	650	650	650		650	650	650	650	650	650	650	650	650	650
	移动台承载能力 Loading Capacity of Bolster	T	/	/	/	20	20	20	25	20		20	25	25	25	20	25	20	25	20	25
滑块底面 Bottom Size of Slide	底面尺寸（左右X前后） Bottom Size of Slide	mm	2770X1250	2770X1250	2800X1600	2800X1600	2800X1600	3200X1600	3600X1800	3200X1600		3200X1600	3600X1800	3600X1800	3600X1800	3200X1600	3600X1800	3200X1600	3600X1800	4000X1800	
	最大上模重量 Max. Upper Die Weight	T	5	5	6	10	10	10	12	10		10	12	12	12	10	12	10	12	10	
侧面开口尺寸（固定台/前移） Side Opening	mm		800	800	800	800	800	800	800	1000		1000	1000	1000	1000	1200	1200	1200	1200	1200	
主电机功率 Main Motor Power	KW		37	37	45	45	45	45	45	55		55	55	55	55	75	75	75	75	75	
气垫 Cushion	公称力 Force	KN	400	500	600	600	600	600	600	800		800	800	800	800	1000	1000	1000	1000	1000	
	行程 Stroke	mm	15~150	15~150	15~150	15~150	15~150	15~150	15~150	20~200		20~200	20~200	20~200	20~200	20~200	20~200	20~200	20~200	20~200	

注：YS2A无导柱导套 Note: YS2A does not adopt the guide rod and bush



# YS2/YS2A 闭式双点压力机

## Straight Side Two-point Press



### 技术参数 Specifications

技术参数 Technical Data		型号 Model	YS2-630					YS2-800					YS2-1000			YS2-1250					YS2-1600	YS2-2000		
名称 Items																								
公称力 Nominal Pressure	KN		6300	6300	6300	6300	8000	8000	8000	8000	8000		8000	8000	10000	10000	10000	12500	12500	12500	12500	12500	16000	20000
公称力行程 Nominal Pressure Stroke	mm		13	13	13	13	13	13	13	13	13		13	13	13	13	13	13	13	13	13	13	13	13
滑块行程 Stroke of Slide	mm		700	700	800	800	500	500	600	600	700		700	800	600	700	800	600	600	700	700	800	700	800
行程次数 Stroke	S.P.M		10~20	10~20	10~20	10~20	10~20	10~20	10~20	10~20	10~20		10~20	10~20	10~20	10~20	10~20	10~20	10~20	10~20	10~20	10~20	10~20	12~18
最大装模高度 Max. Die Set Height	mm		1200	1200	1200	1200	1200	1200	1200	1200	1200		1200	1200	1200	1200	1200	1200	1200	1200	1200	1200	1200	1200
装模高度调节量 Die Height Adjustment	mm		500	500	500	500	500	500	500	500	500		500	500	500	500	500	500	500	500	500	500	500	500
工作台板 Bolster	台板尺寸(左右X前后) Size of Bolster	mm	3600X1800	4000X1800	3600X1800	4000X1800	3600X1800	4000X1800	3600X1800	4000X1800	3600X1800		4000X1800	4000X1800	4000X1800	4500X1800	4000X1800	4000X1800	4500X1800	4000X1800	4500X1800	4000X1800	4500X1800	4800X2000
	形式 Direction of Moving Bolster		前移/侧移 Front/Side Moving	前移/侧移 Front/Side Moving	前移/侧移 Front/Side Moving	前移/侧移 Front/Side Moving	前移/侧移 Front/Side Moving	前移/侧移 Front/Side Moving	前移/侧移 Front/Side Moving	前移/侧移 Front/Side Moving	前移/侧移 Front/Side Moving		前移/侧移 Front/Side Moving	前移/侧移 Front/Side Moving	前移/侧移 Front/Side Moving	前移/侧移 Front/Side Moving	前移/侧移 Front/Side Moving	前移/侧移 Front/Side Moving	前移/侧移 Front/Side Moving	前移/侧移 Front/Side Moving	前移/侧移 Front/Side Moving	前移/侧移 Front/Side Moving	前移/侧移 Front/Side Moving	
	工作面距离地面高度 Height From Floor to Bolster Surface	mm	650	650	650	650	650	650	650	650	650		650	650	650	650	650	650	700	650	700	650	700	700
	移动台承载能力 Loading Capacity of Bolster	T	25	25	25	25	25	25	25	25	25		25	25	25	30	25	25	30	25	30	25	30	40
滑块底面 Bottom Size of Slide	底面尺寸(左右X前后) Bottom Size of Slide	mm	3600X1800	4000X1800	3600X1800	4000X1800	3600X1800	4000X1800	3600X1800	4000X1800	3600X1800		4000X1800	4000X1800	4000X1800	4500X1800	4000X1800	4000X1800	4500X1800	4000X1800	4500X1800	4000X1800	4500X1800	4800X2000
	最大上模重量 Max. Upper Die Weight	T	12	12	12	12	12	12	12	12	12		12	12	12	15	12	12	15	12	15	12	15	20
侧面开口尺寸(固定台/前移) Side Opening	mm		1200	1200	1200	1200	1400	1400	1400	1400	1400		1400	1400	1600	1600	1600	1800	1800	1800	1800	1800	1800	2000
主电机功率 Main Motor Power	KW		75	75	75	75	90	90	90	90	90		90	90	110	110	110	132	132	132	132	132	160	250
气垫 Cushion	公称力 Force	KN	1000	1000	1000	1000	1200	1200	1200	1200	1200		1200	1200	1200	1200	1200	1500	1500	1500	1500	1500	2000	2500
	行程 Stroke	mm	20~200	20~200	20~200	20~200	25~250	25~250	25~250	25~250	25~250		25~250	25~250	25~250	25~250	25~250	25~250	25~250	25~250	25~250	25~250	25~250	30~300



# YS4/YS4L 闭式四点（多连杆）压力机

## H-type Frame Four-point (Link Drive) Press

### 主要功能和特点 Main Structure Features

- ◆ 适合单工程模冲压，或多机串联自动化冲压线；
- ◆ 横梁、滑块、立柱、底座分体钢板焊接，CAE分析获得高刚性机身；
- ◆ 偏心齿轮结构，四点传动；
- ◆ 高精度全程八面导向；
- ◆ 分体气动离合制动器；
- ◆ 高灵敏度液压过载保护；
- ◆ 稀油自动循环润滑；
- ◆ 安全装置齐全，配置光电保护、维修平台、顶部护栏、安全栓等；
- ◆ 选配：自动化设备、双移动台、气垫（液压垫）、吨位仪、夹模器、减震垫、安全门、废料槽、湿式离合器、滑块锁紧等装置。

- ◆ Apply to single-station die or multi-press automatic stamping line.
- ◆ Tie-rod structure, the Crossbeam, slide, columns and base are welded steel, high rigidity frame realized by CAE analysis.
- ◆ Four-point transmission structure with eccentric gear.
- ◆ Full length 8-side long guide rail with high precision.
- ◆ Separate type pneumatic clutch and brake.
- ◆ High sensitive HOLP.
- ◆ Automatic oil cycle lubrication system.
- ◆ Full safety device equipped with photoelectric protection, maintenance platform, safety fence, safety block etc.
- ◆ Optional: Automation equipments, additional moving bolsters, air cushion (Hydraulic cushion), tonnage monitor, die clamps, anti-vibration pads, safety door, scrap chute, wet clutch, slide lock device etc.



### 技术参数 Specifications

技术参数 Technical Data		型号 Model	YS4-500	YS4-630	YS4-800	YS4-1000		YS4-1300		YS4-1600	YS4-2000	YS4L-630	YS4L-800	YS4L-1000	YS4L-1300	YS4L-1600		YS4L-2000	YS4L-2500		
名称 Items																					
公称力 Nominal Pressure	KN		5000	6300	8000	10000	10000	13000	13000	13000		16000	20000	6300	8000	10000	13000	16000	16000	20000	25000
公称力行程 Nominal Pressure Stroke	mm		13	13	13	13	13	13	13	13		13	13	13	13	13	13	13	13	13	13
滑块行程 Stroke of Slide	mm		700	800	900	900	1250	800	800	1100		800	800	800	800	800	1000	900	1300	1000	1400
行程次数 Stroke	S.P.M		10~20	10~20	10~20	10~20	10~20	10~20	10~20	10~20		10~20	10~20	10~20	10~20	10~20	10~20	8~18	8~18	8~18	8~18
最大装模高度 Max. Die Set Height	mm		1400	1400	1400	1400	1500	1400	1400	1400		1400	1400	1200	1200	1200	1300	1400	1530	1530	1530
装模高度调节量 Die Height Adjustment	mm		600	600	600	600	700	600	600	600		600	600	500	500	500	600	600	530	530	530
工作台板 Bolster	台板尺寸（左右X前后） Size of Bolster	mm	4000X2200	4500X2500	4500X2500	4500X2500	4600X2500	5500X2500	4200X2200	4800X2500		5000X2500	5000X2500	4000X2200	4000X2200	4000X2200	4200X2200	4500X2500	5000X2500	5000X2500	5000X2500
	形式 Direction of Moving Bolster		前移/侧移 Front/Side Moving	前移/侧移 Front/Side Moving	前移/侧移 Front/Side Moving	前移/侧移 Front/Side Moving	前移/侧移 Front/Side Moving	前移/侧移 Front/Side Moving	前移/侧移 Front/Side Moving	前移/侧移 Front/Side Moving		前移/侧移 Front/Side Moving	前移/侧移 Front/Side Moving	前移/侧移 Front/Side Moving	前移/侧移 Front/Side Moving	前移/侧移 Front/Side Moving	前移/侧移 Front/Side Moving	前移/侧移 Front/Side Moving	前移/侧移 Front/Side Moving	前移/侧移 Front/Side Moving	前移/侧移 Front/Side Moving
	工作面距离地面高度 Height From Floor to Bolster Surface	mm	700	700	700	700	800	700	750	800		700	750	650	650	650	650	700	800	800	800
	移动台承载能力 Loading Capacity of Bolster	T	30	40	40	40	40	50	40	40		40	50	30	30	30	30	50	60	60	60
滑块底面 Bottom Size of Slide	底面尺寸（左右X前后） Bottom Size of Slide	mm	4000X2200	4500X2500	4500X2500	4500X2500	4600X2500	5500X2500	4200X2200	4800X2500		5000X2500	5000X2500	4000X2200	4000X2200	4000X2200	4200X2200	4500X2500	5000X2500	5000X2500	5000X2500
	最大上模重量 Max. Upper Die Weight	T	15	20	20	20	20	25	20	20		20	25	15	15	15	15	25	25	25	25
侧面开口尺寸（固定台/前移） Side Opening	mm		1200	1200	1400	1600	1600	1800	1800	1800		1800	1800	1400	1400	1600	1800	1800	1800	1800	2000
主电机功率 Main Motor Power	KW		90	110	132	160	200	200	200	250		250	280	110	132	160	200	250	280	315	435
气垫 Cushion	公称力 Force	KN	1000	1200	1500	2000	2000	2000	2000	2000		2500	2500	1200	1500	2000	2000	2500	2500	3000	3500
	行程 Stroke	mm	20~200	25~250	25~250	25~250	25~250	25~250	25~250	25~250		30~300	30~300	25~250	25~250	25~250	25~250	30~300	30~300	30~300	30~300

注：YS4为四点偏心齿轮结构，YS4L为四点多连杆结构。 Note: YS4 adopts the 4-point eccentric gear structure, YS4L adopts the 4-point link drive structure



# YP2/YP2E/YP4E 闭式双点 / 四点连续模压力机

## Straight Side Two-point/ Four-Point Progressive Die Press

### 主要功能和特点 Main Structure Features

- ◆ 适合重负荷连续模、级进模高效连续自动化冲压；
- ◆ 横梁、滑块、立柱、底座分体钢板焊接，CAE分析获得高刚性机身，刚性1/10000；
- ◆ YP2为曲轴结构，YP2E/YP4E为偏心齿轮结构，连杆间距大，抗偏载能力强；
- ◆ 高精度全程八面导向；
- ◆ 气动离合制动器；
- ◆ 高灵敏度液压过载保护；
- ◆ 稀油自动循环润滑；
- ◆ 安全装置齐全，配置光电保护、维修平台、顶部护栏、安全栓等；
- ◆ 选配：自动送料、双移动台、吨位仪、夹模器、一键换模、减震垫、前后安全门、废料槽、湿式离合器、滑块锁紧等装置。

- ◆ Apply to heavy load progressive die stamping with high efficiency.
- ◆ Tie-rod type frame, CrossBeam,slide, uprights,basement are welded steel, high rigidity frame realized by CAE analysis,rigidity 1/10000.
- ◆ YP2 adopts crank-shaft design,YP2E/YP4E adopts eccentric gear structure, with large distance between two connecting rods,strong ability of anti-unbalance loading.
- ◆ Full length 8-side long guide rail with high precision
- ◆ Pneumatic clutch-brake
- ◆ High sensitive HOLF
- ◆ Automatic oil cycle lubrication system
- ◆ Full safety device equipped with photoelectric protection, maintenance platform, safety fence,safety block etc.
- ◆ Optional: Automatic feeding equipment,additional moving bolsters,tonnage monitor,die clamps,fast die change with 1 switch button,anti-vibration pads,safety door,scrap chute,wet clutch, slide lock device etc.



### 技术参数 Specifications

技术参数 Technical Data		型号 Model	YP2-200	YP2-300	YP2-400	YP2-500	YP2-630	YP2-800	YP2-1000	YP2E-630	YP2E-800	YP2E-1000	YP2E-1250	YP4E-800	YP4E-1000	YP4E-1250
名称 Items																
公称力 Nominal Pressure	KN		2000	3000	4000	5000	6300	8000	1000	6300	8000	10000	12500	8000	10000	12500
公称行程 Nominal Pressure Stroke	mm		6	7	7	8	8	10	10	10	10	13	13	10	13	13
滑块行程 Stroke of Slide	mm		250	250	250	300	300	350	350	400	400	500	500	400	500	500
行程次数 Stroke	S.P.M		20~50	20~50	20~50	20~40	20~40	20~35	20~35	20~40	20~40	15~30	15~30	20~40	15~30	15~30
最大装模高度 Max.Die Set Height	mm		600	600	800	900	900	900	900	1000	1100	1200	1200	1100	1200	1200
装模高度调节量 Die Height Adjustment	mm		200	200	300	300	300	300	300	300	300	300	300	300	300	300
工作台板 Bolster	台板尺寸(左右X前后) Size of Bolster	mm	2100X1000	2500X1000	3200X1100	3500X1500	4000X1800	4000X1800	4000X1800	3600X1600	4000X1800	4500X1800	5000X1800	4000X2200	4500X2200	5000X2200
	形式 Moving Direction of Bolster		固定台 Fix	固定台 Fix	固定台 Fix	固定台 Fix	前移 Front	前移 Front	前移 Front	前移 Front	前移 Front	前移 Front	前移 Front	前移 Front	前移 Front	前移 Front
	工作面距离地面高度 Height From Floor to Bolster Surface	mm	800	800	800	800	650	650	650	650	650	650	700	650	650	700
	移动台承载能力 Loading Capacity of Bolster	T	/	/	/	/	25	25	25	20	25	30	35	30	35	40
滑块底面 Bottom Size of Slide	底面尺寸(左右X前后) Bottom Size of Slide	mm	2100X1000	2500X1000	3200X1100	3500X1500	4000X1800	4000X1800	4000X1800	3600X1600	4000X1800	4500X1800	5000X1800	4000X2200	4500X2200	5000X2200
	最大上模重量 Max. Upper Die Weight	T	3	3	4	5	12	12	12	10	12	15	17	15	17	20
侧面开口尺寸(固定台/前移) Side Opening	mm		1300	1300	1400	1400	1600	1600	1600	1400	1600	1600	1600	1800	1800	1800
主电机功率 Main Motor Power	KW		22	30	37	45	55	75	90	75	90	110	132	90	110	132



# YT2E/YT4E/YT4L 多工位压力机

## Transfer Press

### 主要功能和特点 Main Structure Features

- ◆ 适合多工位高效连续自动化冲压;
  - ◆ 横梁、滑块、立柱、底座分体钢板焊接, CAE分析获得高刚性机身;
  - ◆ 偏心齿轮或多连杆结构, 连杆间距大, 抗偏载能力强;
  - ◆ 高精度全程八面导向;
  - ◆ 气动离合制动器;
  - ◆ 高灵敏度液压过载保护;
  - ◆ 稀油自动循环润滑;
  - ◆ 安全装置齐全, 配置光电保护、维修平台、顶部护栏、安全栓等;
  - ◆ 选配: 自动送料、双移动台、气垫、吨位仪、夹模器、一键换模、减震垫、前后安全门、废料槽、湿式离合器、滑块锁紧等装置。
- ◆ Apply to automatic transfer stamping with high efficiency.
  - ◆ Tie-rod structure, the Crossbeam, slide, columns and base are welded steel, high rigidity frame realized by CAE analysis.
  - ◆ Eccentric gear or link drive structure, with large distance between two connecting rods, strong ability of anti-imbalance loading.
  - ◆ Full length 8-side long guide rail with high precision.
  - ◆ Pneumatic clutch-brake.
  - ◆ High sensitive HOLP.
  - ◆ Automatic oil cycle lubrication system.
  - ◆ Full Full safety device equipped with photoelectric protection, maintenance platform, safety fence, safety block etc.
  - ◆ Optional: Automatic feeding equipment, additional moving bolsters, air cushion (Hydraulic cushion), tonnage monitor, die clamps, fast die change with 1 switch button, anti-vibration pads, safety door, scrap chute, wet clutch, slide lock device etc.



### 技术参数 Specifications

名称 Items		型号 Model	YT2E-400	YT2E-500	YT2E-630	YT2E-800	YT2E-1000	YT2E-1250	YT2E-1600		YT4E-1000	YT4E-1250	YT4E-1600	YT4E-2000	YT4E-2500	YT2L-1250	YT4L-1600		YT4L-2000	YT4L-2500	YT4L-3200	
公称力 Nominal Pressure	KN		4000	5000	6300	8000	10000	12500	16000	16000	10000	12500	16000	20000	25000	12500	16000	16000	20000	25000	32000	
公称力行程 Nominal Pressure Stroke	mm		8	10	13	13	13	13	13	13	13	13	13	13	13	13	12.7	12.7	12.7	12.7	12.7	
滑块行程 Stroke of Slide	mm		400	400	500	600	700	700	700	700	600	600	700	800	800	630	762	914	914	914	914	
行程次数 Stroke	S.P.M		15~30	15~30	12~25	12~25	12~25	12~25	12~25	12~25	12~30	12~30	12~25	10~25	10~25	10~30	10~30	10~30	10~25	10~25	10~25	
最大装模高度 Max. Die Set Height	mm		1000	1000	1000	1100	1200	1200	1200	1200	1000	1000	1300	1300	1300	1000	1200	1395	1395	1395	1600	
装模高度调节量 Die Height Adjustment	mm		300	300	400	400	500	500	500	500	300	300	500	500	500	300	410	410	410	410	410	
工作台板 Bolster	台板尺寸(左右X前后) Size of Bolster	mm	2800X1200	3600X1600	4000X1800	5000X1800	5000X1800	5000X1800	5000X1800	6300X1800	5000X2200	5500X2200	6300X2500	6300X2500	6300X2500	6000X1800	5500X2500	6100X2750	6100X2750	6200X2750	7600X2750	
	形式 Direction of Moving Bolster		固定台 Fix	固定台 Fix	前移 Front	前移 Front	前移 Front	前移 Front	前移 Front	前移 Front	前移 Front	前移 Front	前移 Front	前移 Front	前移 Front	前移 Front	前移 Front	前移 Front	前移 Front	前移 Front	前移 Front	前移 Front
	工作面距离地面高度 Height From Floor to Bolster Surface	mm	800	800	650	650	700	700	700	700	700	700	700	700	610	700	610	610	610	610	610	610
	移动台承载能力 Loading Capacity of Bolster	T	/	/	25	30	35	35	35	50	40	50	50	60	80	50	50	60	60	60	80	
滑块底面 Bottom Size of Slide	底面尺寸(左右X前后) Bottom Size of Slide	mm	2800X1200	3600X1600	4000X1800	5000X1800	5000X1800	5000X1800	5000X1800	6300X1800	5000X2200	5500X2200	6300X2500	6100X2750	6100X2750	6000X1800	5500X2500	6100X2750	6100X2750	6100X3050	7600X3050	
	最大上模重量 Max. Upper Die Weight	T	8	10	12	15	17	17	17	25	20	25	25	30	35	25	25	35	35	35	35	
侧面开口尺寸(固定台/前移) Side Opening	mm		1300	1600	2000	2000	2500	2500	2500	2500	2500	2500	3300	3600	3600	2100	3300	3600	3600	3600	3800	
主电机功率 Main Motor Power	KW		45	75	90	110	132	160	200	200	132	160	200	280	350	220	280	280	315	400	450	

\*注: YT2E双点为偏心齿轮结构, YT4E为四点偏心齿轮结构, YT4L为四点多连杆结构  
可选配U型, 为上下流侧公称力60%: 40%偏载分配, 例YT4E-1600U

Note: YT2E adopts 2-point eccentric gear structure, YT4E adopts the 4-point eccentric gear structure, YT4L adopts 4-point link drive structure.  
The optional U type model can allocate the eccentric load pressure 60% : 40%, such like YT4E-1600U model.



# YB4E 闭式四点落料压力机

## Four-point Blanking Press



### 主要功能和特点 Main Structure Features

- ◆ 适合高速落料自动化冲压；
  - ◆ 横梁、滑块、立柱、底座分体钢板焊接，CAE分析获得高刚性机身，刚性1/12000；
  - ◆ 偏心齿轮结构，四点全人字齿传动，噪音低；
  - ◆ 高精度全程八面导向；
  - ◆ 气动离合制动器；
  - ◆ 高灵敏度液压过载保护；
  - ◆ 稀油自动循环润滑；
  - ◆ 安全装置齐全，配置光电保护、维修平台、顶部护栏、安全栓等；
  - ◆ 选配：自动送料、双移动台、吨位仪、夹模器、一键换模、减震垫、前后安全门、废料槽、湿式离合器、滑块锁紧等装置。
- ◆ Apply to high speed automatic blanking line
  - ◆ Tie-rod structure, the Crossbeam, slide, columns and base are welded steel, high rigidity frame realized by CAE analysis, rigidity 1/12000
  - ◆ Eccentric gear structure, with four-point transmission driven by herringbone gear, with low noise level.
  - ◆ Full length 8-side long guide rail with high precision
  - ◆ Pneumatic clutch-brake
  - ◆ High sensitive HOLF
  - ◆ Automatic oil cycle lubrication system
  - ◆ Full safety device equipped with photoelectric protection, maintenance platform, safety fence, safety block etc.
  - ◆ Optional: Automatic feeding equipment, additional moving bolsters, tonnage monitor, die clamps, fast die change with 1 switch button, anti-vibration pads, safety door, scrap chute, wet clutch, slide lock device etc.

### 技术参数 Specifications

技术参数 Technical Data		型号 Model	YB4E-500		YB4E-630		YB4E-800		YB4E-1000	
名称 Items										
公称力 Nominal Pressure	KN		5000	6300	6300	8000	8000	10000		
公称力行程 Nominal Pressure Stroke	mm		6.5	6.5	6.5	6.5	6.5	6.5		
滑块行程 Stroke of Slide	mm		300	300	300	300	300	300		
行程次数 Stroke	S.P.M		15-60	15-60	15-60	15-60	15-60	15-60		
最大装模高度 Max. Die Set Height	mm		1200	1200	1200	1200	1200	1200		
装模高度调节量 Die Height Adjustment	mm		400	400	400	400	400	400		
工作台板 Bolster	台板尺寸 (左右X前后) Size of Bolster	mm	3500X2500	4600X2500	5000X2500	4750X2750	5100X2750	4750X2750		
	形式 Direction of Moving Bolster		前后移 Front and Back	前后移 Front and Back	前后移 Front and Back	前后移 Front and Back	前后移 Front and Back	前后移 Front and Back		
	工作面距离地面高度 Height From Floor to Bolster Surface	mm	800	800	800	800	800	800		
	移动台承载能力 Loading Capacity of Bolster	T	25	40	40	40	40	40		
滑块底面 Bottom Size of Slide	底面尺寸 (左右X前后) Bottom Size of Slide	mm	3500X2500	4600X2500	5000X2500	4750X2750	5100X2750	4750X2750		
	最大上模重量 Max. Upper Die Weight	T	12	20	20	20	20	20		
侧面开口尺寸 (固定台/前移) Side Opening	mm		2200	2500	2500	2750	2750	2750		
主电机功率 Main Motor Power	KW		90	110	110	132	132	160		





# JH31 闭式单点压力机

## Straight Side One-point Press

# JF31 闭式单点压力机

## Straight Side One-point Press



**主要功能和特点 Main Structure Features**

- ◆ 高刚性焊接整体机身;
- ◆ 采用气动干式分体顶杆式离合制动器, 安全可靠;
- ◆ 偏心齿轮结构;
- ◆ 能承受高的集中负荷;
- ◆ 超长导轨设计;
- ◆ 电气控制, 操作简单, 可靠性高。
- ◆ Steel-welded frame, high rigidity, high precision, high energy.
- ◆ Adopt dry type pneumatic separated clutch&brake, simple design, more safe and long life.
- ◆ Eccentric gear press.
- ◆ Withstand high concentrated loadings.
- ◆ Long guiding rail design.
- ◆ Electrical control-simple control, high reliability.

**选配 Optional Accessories:**

- 气垫装置 / Air cushion
- 吨位显示器 / Tonnage monitor
- 变频器 / Frequency converter
- 滑块上部脱料装置 / Upper slide material knockout device
- 湿式离合器 / Wet clutch
- PLC可编程控制系统 / PLC programmable control system



**主要功能和特点 Main Structure Features**

- ◆ 适合重负荷、厚板类零件单冲或级进模连续自动化冲压;
- ◆ 横梁、滑块、立柱、底座分体钢板焊接, CAE分析获得高刚性机身, 刚性1/10000;
- ◆ 偏心齿轮结构, 单点传动;
- ◆ 高精度全程八面导向;
- ◆ 气动离合制动器;
- ◆ 高灵敏度液压过载保护;
- ◆ 稀油自动循环润滑;
- ◆ 安全装置齐全, 配置光电保护、维修平台、顶部护栏、安全栓等;
- ◆ 选配: 自动送料、气垫、吨位仪、夹模器、减震垫、废料槽、湿式离合器、滑块锁紧等装置。
- ◆ Apply to heavy load stamping, thick sheet metal single stamping or progressive die Continuous stamping.
- ◆ Tie-rod structure, the Crossbeam, slide, columns and base are welded steel, high rigidity frame realized by CAE analysis, rigidity 1/10000
- ◆ Eccentric gear structure, single-point drive
- ◆ Full length 8-side long guide rail with high precision
- ◆ Pneumatic clutch-brake
- ◆ High sensitive HOLF
- ◆ Automatic oil cycle lubrication system
- ◆ Full safety device equipped with photoelectric protection, maintenance platform, safety fence, safety block etc.
- ◆ Optional: Automatic feeding equipment, air cushion (Hydraulic cushion), tonnage monitor, die clamps, anti-vibration pads, scrap chute, wet clutch, slide lock device etc.

### 技术参数 Specifications

### 技术参数 Specifications

技术参数 Technical Data		型号 Model	JH31-125	JH31-160	JH31-250	JH31-315	JH31-400	JH31-500
名称 Items								
公称力 Nominal Pressure	KN		1250	1600	2500	3150	4000	5000
公称力行程 Nominal Pressure Stroke	mm		8	9	12	13.5	13.5	13.5
滑块行程 Stroke of Slide	mm		130	160	200	220	250	250
行程次数 Stroke	S.P.M		35	32	28	28	25	25
最大装模高度 Max.Die Set Height	mm		350	380	450	520	550	550
装模高度调节量 Die Height Adjustment	mm		100	140	160	160	160	160
滑块底面 Bottom Size of Slide	左右 L-R	mm	500	500	700	700	810	810
	前后 F-B	mm	550	550	670	670	810	810
工作台板 Bolster	左右 L-R	mm	700	700	850	850	990	990
	前后 F-B	mm	750	750	900	900	1060	1060
主电机功率 Main Motor Power	KW		11	15	22	30	37	45

技术参数 Technical Data		型号 Model	JF31-315	JF31-400	JF31-500	JF31-630	JF31-800	JF31-1000	JF31-1250	JF31-1600
名称 Items										
公称力 Nominal Pressure	KN		3150	4000	5000	6300	8000	10000	12500	16000
公称力行程 Nominal Pressure Stroke	mm		10.5	13	13	13	13	13	13	13
滑块行程 Stroke of Slide	mm		315	400	400	400	500	500	500	500
行程次数 Stroke	S.P.M		15~20	15~20	15~18	12~18	10~16	10~14	9~12	9~12
最大装模高度 Max.Die Set Height	mm		490	550	600	700	700	800	800	850
装模高度调节量 Die Height Adjustment	mm		200	250	250	250	315	315	315	315
导轨间距离 Distance Between Guide	mm		1120	1280	1330	1700	1870	1870	1880	1920
工作台板 Size of Table	左右 L-R	mm	1100	1240	1240	1600	1800	1800	1800	1800
	前后 F-B	mm	1100	1200	1200	1450	1600	1600	1600	1600
工作台板厚度 Bolster Thickness	mm		140	160	200	220	240	260	280	300
滑块底面 Bottom Size of Slide	左右 L-R	mm	1070	1230	1230	1600	1800	1800	1800	1800
	前后 F-B	mm	960	1000	1000	1450	1600	1600	1600	1600
气垫 (选配) Cushion(opt.)	力 Pressure	KN	200	200	500	1000	1200	1200	1200	1200
	行程 Stroke	mm	200	200	200	200	250	250	250	250
侧面开口尺寸 Side Opening	mm		480	500	500	600	800	800	1000	1000
刚性打料行程 (选配) Stroke of Knock-out	mm		110	130	150	150	200	200	200	250
主电机功率 Main Motor Power	KW		30	45	55	75	75	110	110	132

注: 630T及以下为整体焊接机身, 800T及以上为分体焊接机身

Note: Capacity ≤630T, adopt One-piece welding frame, Capacity ≥800T, adopt tie-rod type welding frame.



# YPM 闭式双点连续模压力机

## Straight Side Two-point Press

# YM 连杆式双点精密压力机

## Link Drive Two-point Precision Press



### 主要功能和特点 Main Structure Features

- ◆ 适合重负荷连续模、级进模高效连续自动化冲压；
- ◆ 横梁、滑块、立柱、底座分体钢板焊接，CAE分析获得高刚性机身，刚性1/10000；
- ◆ 偏心轴或偏心齿轮结构，连杆间距大，抗偏载能力强；
- ◆ 高精度全程八面导向；
- ◆ 气动离合制动器；
- ◆ 高灵敏度液压过载保护；
- ◆ 稀油自动循环润滑；
- ◆ 安全装置齐全，配置光电保护、维修平台、顶部护栏、安全栓等；
- ◆ 选配：自动送料、双移动台、吨位仪、夹模器、一键换模、减震垫、前后安全门、废料槽、湿式离合器、滑块锁紧等装置。
- ◆ Apply to heavy load progressive die stamping with high efficiency.
- ◆ Tie-rod structure, the Crossbeam, slide, columns and base are welded steel, high rigidity frame realized by CAE analysis, rigidity 1/10000
- ◆ Eccentric shaft or eccentric gear structure, with large distance between two connecting rods, strong ability of anti-unbalance loading.
- ◆ Full length 8-side long guide rail with high precision
- ◆ Pneumatic clutch-brake
- ◆ High sensitive HOLF
- ◆ Automatic oil cycle lubrication system
- ◆ Full safety device equipped with photoelectric protection, maintenance platform, safety fence, safety block etc.
- ◆ Optional: Automatic feeding equipment, additional moving bolsters, tonnage monitor, die clamps, fast die change with 1 switch button, anti-vibration pads, safety door, scrap chute, wet clutch, slide lock device etc.

### 技术参数 Specifications

技术参数 Technical Data		型号 Model	YPM-630		YPM-800		YPM-1000		YPM-1250		
名称 Items											
公称力 Nominal Pressure	KN		6300	6300	8000	8000	8000	10000	10000	12500	12500
公称力行程 Nominal Pressure Stroke	mm		8	13	10	13	13	13	13	13	13
滑块行程 Stroke of Slide	mm		300	400	350	400	400	400	500	500	500
行程次数 Stroke	S.P.M		20~40	20~40	20~35	15~25	15~25	15~25	15~25	15~25	15~25
最大装模高度 Max. Die Set Height	mm		900	1000	1100	1100	1100	1200	1200	1200	1200
装模高度调节量 Die Height Adjustment	mm		300	400	400	400	400	400	400	400	400
工作台板 Bolster	台板尺寸(左右X前后) Size of Bolster	mm	3600X1600	4000X1800	4000X1800	4000X1800	4500X1800	4500X1800	4500X1800	4500X1800	5000X1800
	形式 Direction of Moving Bolster		前移 Front	前移 Front	前移 Front	前移 Front	前移 Front	前移 Front	前移 Front	前移 Front	前移 Front
	工作面距离地面高度 Height From Floor to Bolster Surface	mm	650	650	650	650	650	650	650	650	700
	移动台承载能力 Loading Capacity of Bolster	T	25	25	25	25	30	30	30	30	35
滑块底面 Bottom Size of Slide	底面尺寸(左右X前后) Bottom Size of Slide	mm	3600X1600	4000X1800	4000X1800	4000X1800	4500X1800	4500X1800	4500X1800	4500X1800	5000X1800
	最大上模重量 Max. Upper Die Weight	T	12	12	12	12	15	15	15	15	17
侧面开口尺寸(固定台/前移) Side Opening	mm		1600	1600	1600	1600	1600	1600	1600	1600	1600
主电机功率 Main Motor Power	KW		75	75	75	75	75	110	110	132	132



### 主要功能和特点 Main Structure Features

- ◆ 双变形肘杆式驱动；
- ◆ 适用厚板材精密冷成型，适合连续模、级进模自动化冲压；
- ◆ 加强型框架式高刚性机身和台板；
- ◆ 滑块保持在下死点停留40度左右；
- ◆ 最大限度的延长制品成型时间；
- ◆ 确保金属制品的塑性成型；
- ◆ 实现精冲加工的光滑冲断面；
- ◆ 能够生产垂直度和平面度要求较高的制品；
- ◆ 延长模具寿命，减少模具维修。
- ◆ With two knuckle structure;
- ◆ Suitable for thick metal sheets, with continuous/ progressive dies at automatic punching;
- ◆ Extra strengthened High rigidity frame and table;
- ◆ Slide can stay at BDC for round 40 degree;
- ◆ Extend molding time by most limit;
- ◆ Guarantee plastic forming of metal;
- ◆ Obtain the smooth fracture surface in fine blanking;
- ◆ Can produce the workpieces which require High Perpendicularity and flatness;
- ◆ Prolong die life and reduce die maintenance.

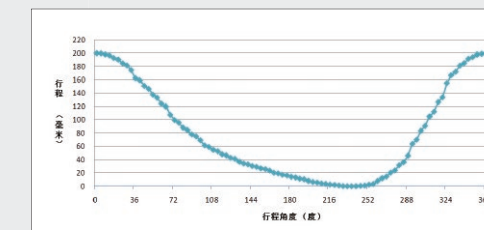

YM-600 行程运动曲线图 YM-600 Stroke Motion Curve

### 技术参数 Specifications

技术参数 Technical Data		型号 Model	YM-200	YM-300	YM-450	YM-600	YM-800	YM-1000
名称 Items								
公称力 Nominal Pressure	KN		2000	3000	4500	6000	8000	10000
公称力行程 Nominal Pressure Stroke	mm		7	7	7	7	10	10
滑块行程 Stroke of Slide	mm		150	150	150	200	200	200
行程次数 Stroke	S.P.M		40~80	40~80	35~70	40~60	35~50	30~40
最大装模高度 Max. Die Set Height	mm		450	450	500	550	550	600
装模高度调节量 Die Height Adjustment	mm		120	120	120	150	150	150
工作台板 Size of Table	左右 L-R	mm	1700	2000	2000	2400	2800	3000
	前后 F-B	mm	800	900	1000	1200	1300	1400
滑块底面 Bottom Size of Slide	左右 L-R	mm	1700	2000	2000	2400	2800	3000
	前后 F-B	mm	700	800	900	1000	1200	1300
主电机功率 Main Motor Power	KW		37	45	75	90	110	132
供给气压 Air Supply	MPa		0.5	0.5	0.5	0.5	0.5	0.5



# JH21 开式固定台高性能压力机

## C-type Frame Fixed Table Press



### 主要功能和特点 Main Structure Features

- ◆ 高精度，满足JIS1级标准；
  - ◆ 高刚性焊接机身；
  - ◆ 高精度六面长导轨；
  - ◆ 干式气动摩擦离合器；
  - ◆ 进口安全双联电磁阀；
  - ◆ 高灵敏度液压过载保护；
  - ◆ 浓油自动润滑系统；
  - ◆ 变频调速；
  - ◆ 装模高度自动调节(25T、45T为手动调节)；
  - ◆ PLC集中控制，操作便利；
  - ◆ 选配：输出轴、气垫、滑块打料、自动送料等装置。
- ◆ High accuracy, reach JIS1;
  - ◆ High rigidity, steel-welded frame;
  - ◆ High precision, 6-side long guide rail;
  - ◆ Dry Type pneumatic clutch-brake unit;
  - ◆ Imported safety dual-solenoid valve for clutch;
  - ◆ High sensitive HOLP;
  - ◆ Automatic grease lubrication system;
  - ◆ (FDI)Frequency drive inverter;
  - ◆ Die height auto matil adjustment (25T, 45T manual adjustment);
  - ◆ PLC system;
  - ◆ Optional components: Output shaft, air cushion, slide knockout device, automatic feeder, etc.

### 技术参数 Specifications

名称 Items	技术参数 Technical Data	型号 Model	JH21-25		JH21-45		JH21-60		JH21-80		JH21-110		JH21-125		JH21-160		JH21-200		JH21-250		JH21-315		JH21-400		
			L	S	L	S	L	S	L	S	L	S	L	S	L	S	L	S	L	S	L	S	L	S	L
公称力 Nominal Pressure	KN		250	450	600	800	1100	1250	1600	2000	2500	3150	4000												
公称力行程 Nominal Pressure Stroke	mm		2.8	3.2	4	4.5	5	5	6	6	7	8	8												
滑块行程 Stroke of Slide	mm		80	50	100	70	120	80	140	90	160	100	180	110	200	130	220	150	250	180	250	180	250	180	
行程次数 Stroke	无极调速 Variable	S.P.M	70-100	80-130	60-90	70-110	50-80	60-100	40-75	50-90	35-70	45-80	35-65	45-80	30-55	35-70	25-50	30-60	25-45	30-50	25-40	25-35	25-35		
	单速 Single	S.P.M	90	110	80	100	70	90	60	80	60	80	55	70	50	60	45	50	40	45	35	30			
最大装模高度 Max. Die Set Height	mm		250	265	270	285	300	320	320	345	350	380	370	400	400	435	450	485	500	535	550	585	550	585	
装模高度调节量 Die Height Adjustment	mm		50	60	70	80	90	90	100	110	110	120	120												
喉口深度 Depth of Throat	mm		210	230	270	290	350	370	390	420	430	430	430												
立柱间距离 Distance Between Uprights	mm		450	500	520	600	680	710	720	830	850	1000	1000												
滑块底面 Bottom Size of Slide	左右 L-R	mm	360	410	480	560	620	620	700	850	880	950	950												
	前后 F-B	mm	250	340	400	430	520	520	580	650	700	700	700												
模柄孔 Hole for Punch Shank	直径 Diameter	mm	Φ40	Φ50	Φ50	Φ60	Φ70	Φ70	Φ70	Φ70	Φ70	Φ70	Φ70												
	深度 Depth	mm	60	60	60	80	80	80	100	100	100	100	100												
工作台板 Size of Table	左右 L-R	mm	710	810	870	1000	1100	1120	1260	1400	1500	1650	1800												
	前后 F-B	mm	400	440	520	560	680	720	760	820	840	840	840												
	厚度 Thickness	mm	70	80	90	100	110	120	140	160	180	180	180												
工作台孔 Size of Opening in Table	直径 Diameter	mm	Φ100	Φ150	Φ150	Φ150	Φ160	Φ160	Φ180	Φ200	Φ250	Φ250	Φ250												
主电机功率 Main Motor Power	KW		3	5.5	5.5	7.5	11	11	15	18.5	22	30	37												

### 机床外形尺寸图 Outline Size Diagram

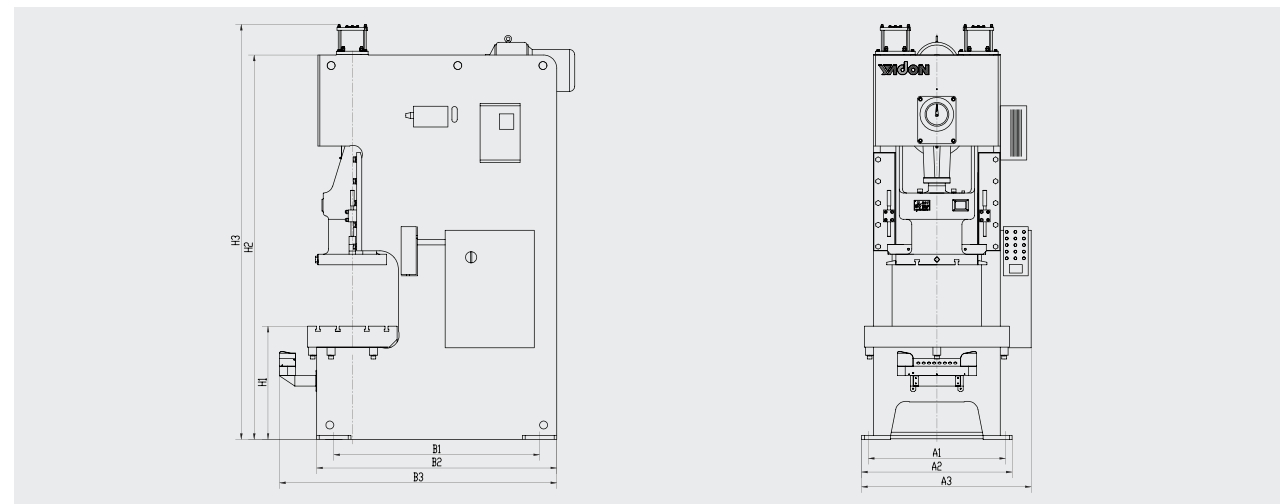

### 机床外形尺寸参数 Parameters of Outline Size

型号参数 Model	JH21-25	JH21-45	JH21-60	JH21-80	JH21-110	JH21-125	JH21-160	JH21-200	JH21-250	JH21-315	JH21-400
地脚螺栓尺寸A1×B1 Anchor Bolt Size A1×B1	640×860	750×950	840×1120	920×1270	1040×1560	1070×1645	1200×1720	1330×1900	1420×2130	1550×(1100+1100)	1600×(1125+1125)
安装尺寸A2×B2 Install Size A2×B2	700×1040	825×1130	940×1300	1010×1450	1140×1820	1170×1945	1300×1980	1430×2170	1520×2410	1660×2520	1740×2600
最大尺寸A3×B3 Max Size A3×B3	900×1400	1030×1450	1100×1650	1180×1800	1310×2200	1350×2300	1470×2350	1590×2600	1700×2800	1750×2600	1810×2650
操作台高度H1 Table Height H1	740	750	790	800	810	820	875	960	1030	1030	1030
机身高度H2 Frame Height H2	2015	2190	2460	2655	2865	2895	3115	3450	3755	4015	4045
总高度H3 Height H3	2160	2250	2550	2730	3150	3170	3350	3650	3850	4350	4450

### 滑块底面 Slide Bottom

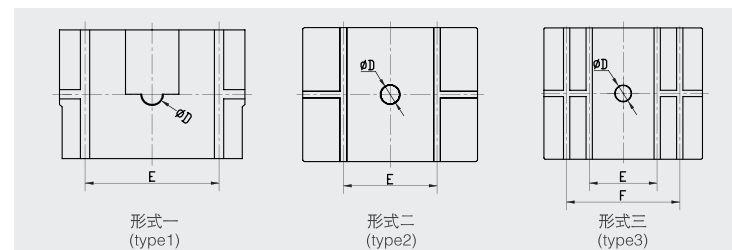

### T型槽 T Groove

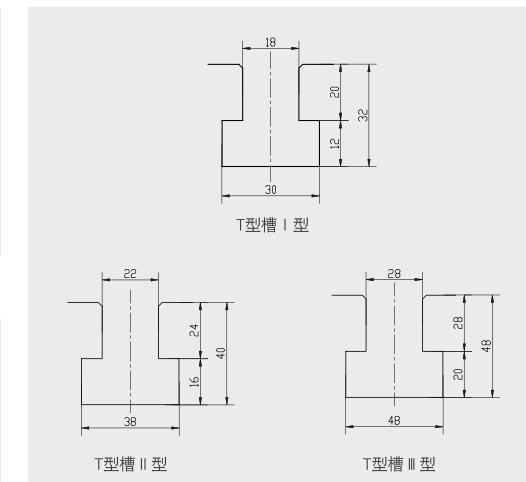

### 工作台板 Working Table

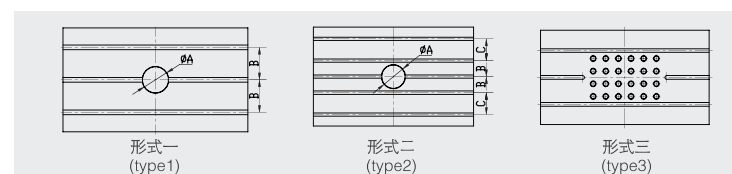

型号参数 Model	JH21-25	JH21-45	JH21-60	JH21-80	JH21-110	JH21-125	JH21-160	JH21-200	JH21-250	JH21-315	JH21-400
ΦA	100	150	150	150	160	160	180	200	250	250	250
B	125	150	150	150	110	110	150	175	175	175	175
C	-	-	-	-	150	150	150	175	175	150	150
ΦD	40	50	50	60	70	70	70	70	70	70	70
E	260	300	300	300	300	300	300	350	350	350	350
F	-	-	-	-	-	-	500	700	700	700	700
T型槽 T-Groove	I	I	II	II	II	II	III	III	III	III	III



# JK21 开式固定台高性能压力机

## C-type Frame Fixed Table Press



### 主要功能和特点 Main Structure Features

- ◆ 高精度，满足JIS1级标准；
  - ◆ 高刚性焊接机身；
  - ◆ 固锁式六面导轨；
  - ◆ 干式气动摩擦离合器；
  - ◆ 安全双联电磁阀；
  - ◆ 高灵敏度液压过载保护；
  - ◆ 浓油自动润滑系统；
  - ◆ 变频调速；
  - ◆ 装模高度自动调节（25T，45T，60T为手动调节）；
  - ◆ 多功能高亲和力电控系统；
  - ◆ 选配：输出轴，气垫，滑块打料等装置。
- ◆ High precision, meeting jis1 standard;
  - ◆ High rigidity welded fuselage;
  - ◆ Locking six side guide rail;
  - ◆ Dry pneumatic friction clutch;
  - ◆ Safety double solenoid valve;
  - ◆ High sensitivity hydraulic overload protection;
  - ◆ Concentrated oil automatic lubrication system;
  - ◆ Frequency control;
  - ◆ Automatic adjustment of mold height (25t, 45t and 60t are manual adjustment);
  - ◆ Multifunctional high affinity electronic control system;
  - ◆ Optional: output shaft, air cushion, sliding block etc.

### 技术参数 Specifications

名称 Items	型号 Model	JK21-25		JK21-45		JK21-60		JK21-80		JK21-110		JK21-160		JK21-200		JK21-260	
		L	S	L	S	L	S	L	S	L	S	L	S	L	S	L	S
公称力 Nominal Pressure	KN	250	450	600	800	1100	1600	2000	2600								
公称力行程 Nominal Pressure Stroke	mm	3.2	3.2	4	5	5	6	6	6.5								
滑块行程 Stroke of Slide	mm	60	30	80	50	120	60	150	70	180	80	200	90	200	100	250	150
行程次数 Stroke	S.P.M	60~140	130~200	40~100	100~160	35~90	90~120	35~80	80~120	30~60	60~90	20~50	40~80	20~50	40~75	20~40	40~50
最大装模高度 Max. Die Set Height	mm	200	215	250	265	310	340	340	380	360	410	460	510	450	510	500	550
装模高度调节量 Die Height Adjustment	mm	50		60		75		80		80		100		110		120	
喉口深度 Depth of Throat	mm	155		225		255		280		305		405		415		430	
立柱间距离 Distance Between Uprights	mm	418		502		526		534		616		660		800		890	
上工作台 Size of Table	左右 L-R	mm	470	560	700	770	910	990	1130	1130							
	前后 F-B	mm	230	300	360	420	470	550	630	700							
模柄孔直径 Hole for Punch Shank	mm	40	40	50	50	50	50	65	65	65							
工作台板 Size of Table	左右 L-R	mm	680	850	900	1000	1150	1250	1400	1500							
	前后 F-B	mm	300	440	500	550	600	800	820	840							
	厚度 Thickness	mm	70	80	80	90	110	140	160	180							
落料孔 Blanking Hole	左右 L-R	mm	240	300	320	360	400	440	480	520							
	前后 F-B	mm	120	150	160	180	200	220	240	260							
主电机功率 Main Motor Power	KW	4	5.5	5.5	7.5	11	15	18.5	22								

### 机床外形尺寸图 Outline Size Diagram

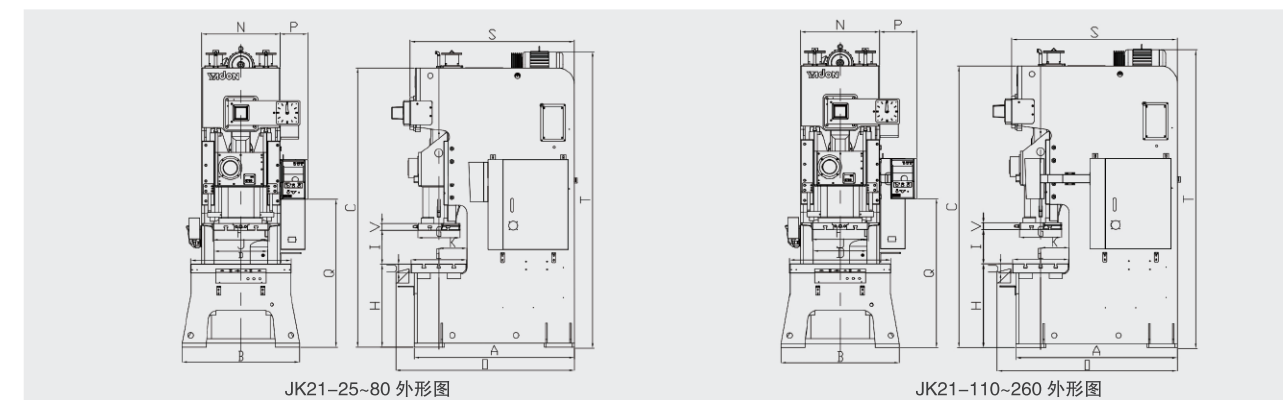

### 机床外形尺寸参数 Parameters of Outline Size

型号参数	JK21-25		JK21-45		JK21-60		JK21-80		JK21-110		JK21-160		JK21-200		JK21-260	
	L	S	L	S	L	S	L	S	L	S	L	S	L	S	L	S
A	1150		1400		1420		1595		1720		2140		2440		2615	
B	840		950		1000		1170		1290		1390		1680		1850	
C	2010		2230		2573		2796		2990		3420		3793		4210	
D	680		850		900		1000		1150		1250		1400		1500	
E	300		440		500		550		600		800		820		840	
F	300		400		500		560		650		700		850		950	
G	250		340		400		420		470		550		630		700	
H	795		790		785		830		830		900		995		1030	
I	200	215	250	265	310	340	340	380	360	410	460	510	450	510	500	550
J	418		502		526		534		616		660		800		890	
K	155		225		255		280		305		405		415		430	
N	540		670		720		780		920		1000		1160		1300	
O	1334		1584		1604		1779		1904		2324		2624		2799	
P	240		240		240		240		325		325		325		325	
Q	1291		1291		1341		1458		1482		1842		1817		1847	
S	1158		1385		1385		1635		1775		2155		2475		2730	
T	2105		2421		2704		2948		3210		3600		4060		4202	
U	70		80		80		90		110		140		160		180	
V	50		60		70		70		80		90		90		100	

### 工作台板 Working Table 滑块底面 Slide Bottom

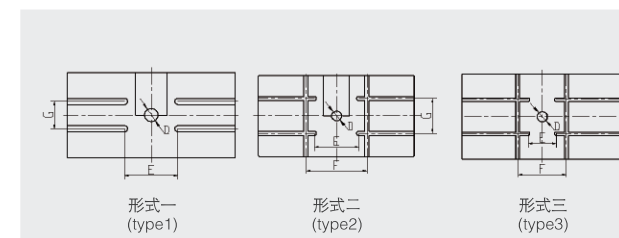
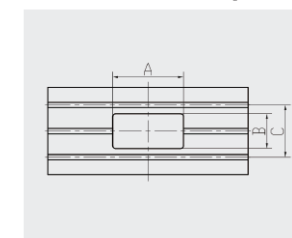

### T型槽 T Groove

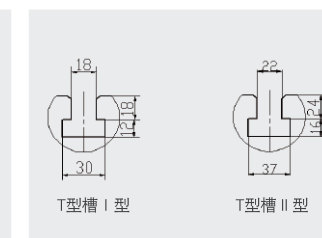

Model	JK21-25	JK21-45	JK21-60	JK21-80	JK21-110	JK21-160	JK21-200	JK21-260
A	240	300	320	360	400	440	480	520
B	120	150	160	180	200	220	240	260
C	80	120	160	180	220	220	300	300
D	38.1	28.1	50	50	50	65	65	65
E	150	210	-	220	220	175	200	200
F	-	-	220	300	300	300	420	420
G	80	120	160	180	220	220	300	300
T型槽 T-Groove	I	I	II	II	II	II	II	II



# JL21 开式固定台高性能压力机

## C-type Frame Fixed Table Press



### 主要功能和特点 Main Structure Features

- ◆ 行程八档可调, 适用广泛;
- ◆ 高精度, 满足JIS1级标准;
- ◆ 高刚性焊接机身;
- ◆ 高精度八面长导轨;
- ◆ 干式气动摩擦离合器;
- ◆ 进口安全双联电磁阀;
- ◆ 高灵敏度液压过载保护;
- ◆ 稀油自动润滑;
- ◆ 装模高度电动调节 (16T、25T为手动调节);
- ◆ PLC集中控制, 操作便利;
- ◆ 选配: 输出轴、气垫、滑块打料、自动送料等装置。
- ◆ 8-step variable Stroke length;
- ◆ High accuracy, reach JIS1;
- ◆ High rigidity, steel-welded frame;
- ◆ High precision, 8-side long guide rail;
- ◆ Dry type pneumatic clutch-brake unit;
- ◆ Imported safety dual-solenoid valve for clutch;
- ◆ High sensitive HOPP;
- ◆ Automatic oil cycle lubrication system;
- ◆ Die height auto matil adjustment (25T manual adjustment);
- ◆ PLC system;
- ◆ Optional components: output shaft, air cushion, slide knockout device, automatic feeder, etc.

### 技术参数 Specifications

名称 Items	技术参数 Technical Data	型号 Model	JL21-16	JL21-25A	JL21-45A	JL21-63A	JL21-80A	JL21-100A	JL21-125	JL21-160A	JL21-200	JL21-250	JL21-315	JL21-400
公称力 Nominal Pressure	KN		160	250	450	630	800	1000	1250	1600	2000	2500	3150	4000
公称力行程 Nominal pressure Stroke	mm		3	3	4	4	4	5	5	6	7	8	8	8
滑块行程 Stroke of Slide	mm		8.3~80	10.5~100	11.5~110	12.5~120	12.5~120	15~140	18.6~150	16.5~160	18.7~180	23~220	250	250
行程次数 Stroke	S.P.M		85~140	70~120	60~100	50~80	50~80	45~65	42~60	35~55	30~50	30~45	25~40	25~35
最大装模高度 Max. Die Set Height	mm		220	250	290	300	300	360	400	460	480	500	550	550
装模高度调节量 Die Height Adjustment	mm		50	50	70	80	80	90	90	100	110	120	120	120
喉口深度 Depth of Throat	mm		170	185	235	260	260	320	320	330	410	410	480	480
立柱间距离 Distance Between Uprights	mm		380	440	510	570	560	570	600	690	820	820	1050	1050
滑块底面 Bottom Size of Slide	左右 L-R	mm	400	460	500	600	600	700	700	790	900	950	1300	1300
	前后 F-B	mm	240	270	300	350	350	400	400	460	570	620	720	720
模柄孔 Hole for Punch Shank	直径 Diameter	mm	Φ30	Φ40	Φ50	Φ50	Φ50	Φ60	Φ60	Φ70	Φ70	Φ70	Φ70	Φ70
	深度 Depth	mm	50	60	60	60	60	80	80	80	80	100	100	100
工作台板 Size of Table	左右 L-R	mm	600	700	800	850	900	1000	1100	1200	1350	1400	1700	1850
	前后 F-B	mm	320	350	450	500	500	630	630	650	800	800	940	940
	厚度 Thickness	mm	60	70	80	90	90	125	150	180	200	200	200	200
工作台孔 Size of Opening in Table	直径 Diameter	mm	Φ110	Φ110	Φ110	Φ125	Φ125	Φ125	Φ140	Φ160	Φ180	Φ180	Φ250	Φ250
主电机功率 Single Speed Motor Power	KW		2.2	3	5.5	7.5	7.5	11	15	15	22	30	30	37

### 机床外形尺寸图 Outline Size Diagram

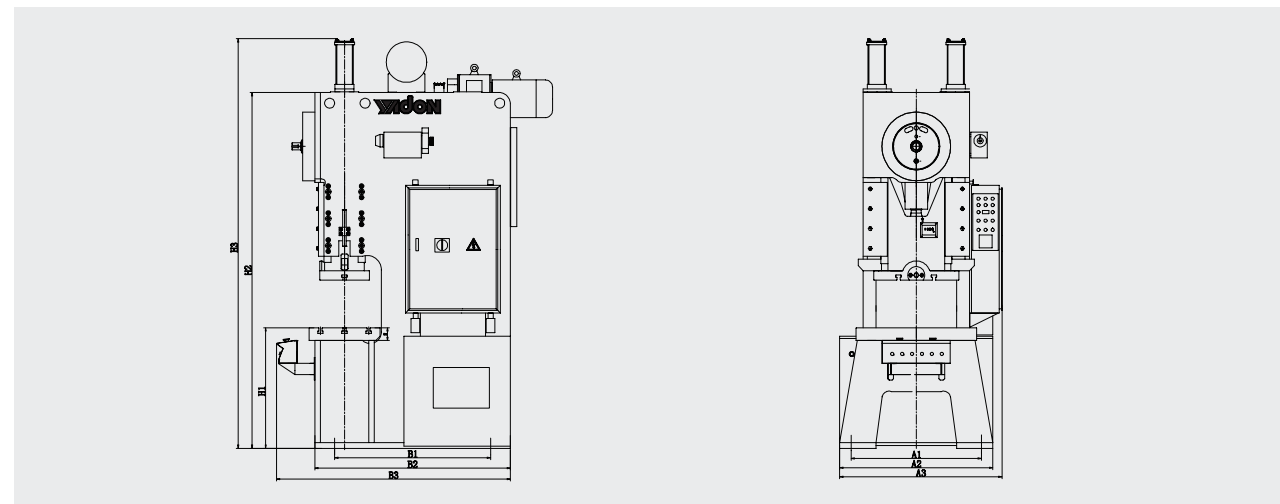

### 机床外形尺寸参数 Parameters of Outline Size

型号参数 Model	JL21-16	JL21-25A	JL21-45A	JL21-63A	JL21-80A	JL21-100A	JL21-125	JL21-160A	JL21-200	JL21-250
地脚螺栓尺寸A1×B1 Anchor Bolt Size A1×B1	660×710	710×795	820×925	920×1100	970×1100	1050×1180	1080×1380	1150×1310	1300×1670	1360×1900
安装尺寸A2×B2 Install Size A2×B2	780×910	890×1015	970×1160	1080×1380	1130×1380	1180×1580	1210×1780	1350×1710	1500×2170	1500×2400
最大尺寸A3×B3 Max Size A3×B3	920×1410	1020×1515	1090×1660	1190×1880	1240×1880	1290×2080	1320×2280	1460×2210	1675×2670	1675×2900
操作台高度H1 Table Height H1	760	790	795	850	850	850	875	900	950	950
机身高度H2 Frame Height H2	1820	2040	2220	2510	2510	2670	2735	3120	3430	3740
总高度H3 Total Height H3	2200	2450	2600	2950	2950	3080	3150	3550	3980	4300

### 滑块底面 Slide Bottom

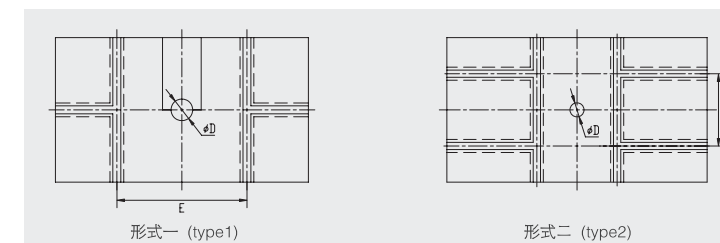

### T型槽 T Groove

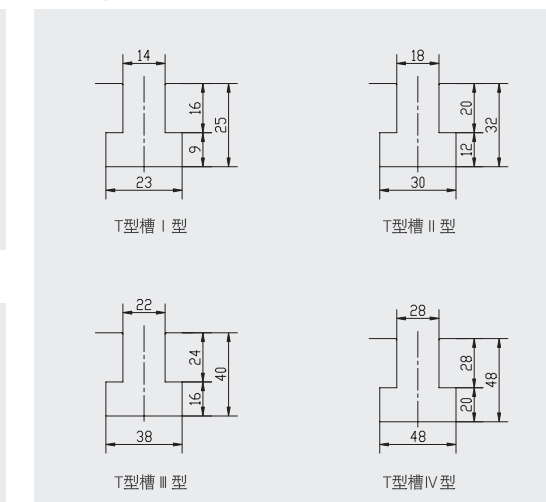

### 工作台板 Working Table

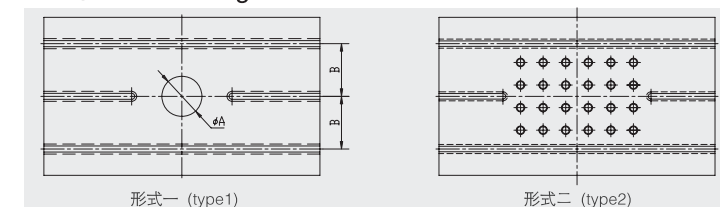

型号参数 Model	JL21-16	JL21-25A	JL21-45A	JL21-63A	JL21-80A	JL21-100A	JL21-125	JL21-160A	JL21-200	JL21-250
ΦA	110	110	110	125	125	125	140	160	180	180
B	120	120	140	170	170	260	260	270	300	300
ΦD	30	40	50	50	50	60	60	70	70	70
E	200	200	250	250	250	360	360	360	450	400
F	-	-	-	-	-	-	-	-	300	300
T型槽 T-Groove	I	II	II	III	III	III	III	IV	IV	IV



# J25 开式双点压力机

## C-type Frame Double-crank Press



### 主要功能和特点 Main Structure Features

- ◆ 高刚性双曲轴逆向运转，抵消侧向力；
  - ◆ 左右抗偏心负荷强；
  - ◆ 高精度，满足JIS1级标准；
  - ◆ 高刚性焊接机身；
  - ◆ 高精度六面长导轨；
  - ◆ 气动摩擦离合器；
  - ◆ 进口安全双联电磁阀；
  - ◆ 高灵敏度液压过载保护；
  - ◆ 浓油自动润滑；
  - ◆ 变频调速；
  - ◆ PLC、编码器、机械凸轮控制；
  - ◆ 选配：输出轴、气垫、滑块打料、自动送料等装置。
- ◆ High rigidity, reverse running double crank, counteract the side force;
  - ◆ High off-set load capability in L-R direction;
  - ◆ High accuracy, reaches JIS1;
  - ◆ High rigidity, steel welded frame;
  - ◆ High precision, 6-side long guide rail;
  - ◆ Pneumatic clutch-brake unit;
  - ◆ Imported safety dual-solenoid valve for clutch;
  - ◆ High sensitive HOLF;
  - ◆ Automatic grease lubrication system;
  - ◆ FDI (frequency drive inverter);
  - ◆ PLC, encoder, cam controller;
  - ◆ Optional components: output shaft, air cushion, slide knockout device, automatic feeder, etc.

### 机床外形尺寸图 Outline Size Diagram

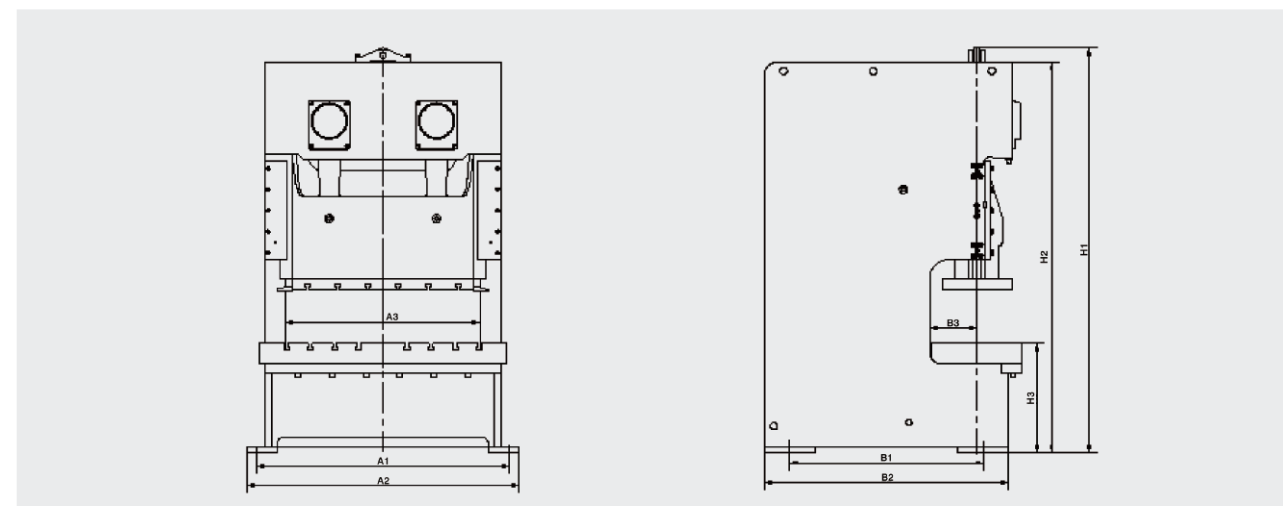

### 机床外形尺寸参数 Parameters of Outline Size

型号参数 Model	J25-80	J25-110	J25-160	J25-200	J25-250	J25-315
A1	1700	1840	2020	2470	2670	2840
A2	1850	1990	2150	2620	2820	2990
A3	1370	1470	1610	1960	2100	2230
B1	1290	1350	1540	1715	2020	2285
B2	1670	1750	1940	2180	2490	2785
B3	310	350	390	430	470	470
H1	2990	3150	3430	3760	4290	4540
H2	2870	3020	3310	3640	4130	4370
H3	860	895	950	975	1095	1200

### 技术参数 Specifications

名称 Items	技术参数 Technical Data	型号 Model	J25-80		J25-110		J25-160		J25-200		J25-250		J25-315	
			L	S	L	S	L	S	L	S	L	S	L	S
公称力 Nominal Pressure	KN		800		1100		1600		2000		2500		3150	
公称力行程 Nominal Pressure Stroke	mm		4.5	2.5	5	3	6	3	7	4	7	4	8	5
滑块行程 Stroke of Slide	mm		160	90	180	110	200	130	230	150	250	180	250	180
行程次数 Stroke	S.P.M		40~75	50~90	35~65	45~80	30~50	35~65	25~45	30~55	20~40	30~50	20~35	25~45
最大装模高度 Max. Die Set Height	mm		380	415	400	435	450	485	500	540	550	585	550	585
装模高度调节量 Die Height Adjustment	mm		80		90		100		110		120		120	
喉口深度 Depth of Throat	mm		310		350		390		430		470		470	
立柱间距离 Distance Between Uprights	mm		1370		1470		1610		1960		2100		2230	
滑块底面 Bottom Size of Slide	左右 L-R	mm	1200		1360		1500		1850		2000		2100	
	前后 F-B	mm	460		520		580		650		700		700	
工作台板 Size of Table	左右 L-R	mm	1650		1880		2040		2420		2600		2720	
	前后 F-B	mm	600		680		760		840		920		920	
主电机功率 Main Motor Power	KW		11		15		22		22		30		37	

### 滑块底面 Slide Bottom

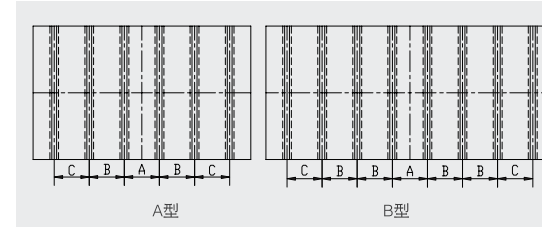

### 工作台板 Working Table

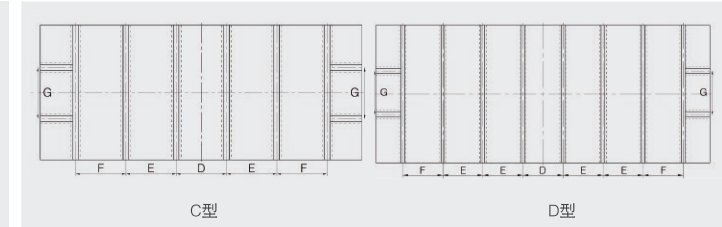

型号 Model	J25-80	J25-110	J25-160	J25-200	J25-250	J25-315
A	175	200	250	250	250	250
B	175	200	250	250	250	250
C	175	200	250	200	250	250
D	175	200	250	250	250	250
E	175	200	250	250	250	250
F	175	200	250	200	250	250
G	300	300	400	400	500	500
滑块底面 Slide bottom	A型	A型	A型	B型	B型	B型
台板台面 Working Table	C型	C型	C型	D型	D型	D型
T型槽 T-Groove	I型	II型	II型	II型	II型	II型

### T型槽 T Groove

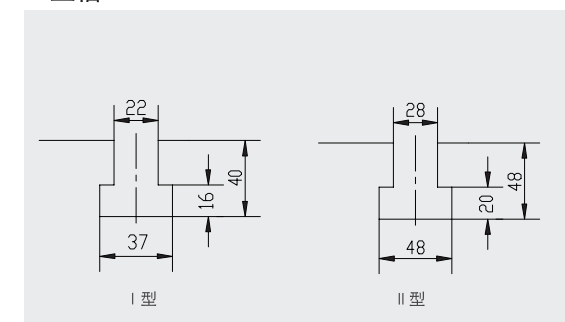



# YS1/YS1Z 闭式单点压力机

## Straight Side Single Crank Press



### 主要功能和特点 Main Structure Features

- ◆ 高精度，满足JIS1级标准；
  - ◆ 闭式高刚性焊接机身；
  - ◆ 高精度八面长导轨；
  - ◆ 干式气动摩擦离合器；
  - ◆ 进口安全双联电磁阀；
  - ◆ 高灵敏度液压过载保护；
  - ◆ 稀油自动润滑；
  - ◆ 变频调速；
  - ◆ PLC集中控制，操作便利；
  - ◆ 选配：输出轴、气垫、滑块打料、自动送料等装置。
- ◆ High accuracy, reaches JIS1;
  - ◆ Straight side structure and High rigidity steel welded frame;
  - ◆ High precision, 8-side long guide rail;
  - ◆ Dry type pneumatic clutch-brake unit;
  - ◆ Imported safety dual-solenoid valve for clutch;
  - ◆ High sensitive HOLP;
  - ◆ Automatic oil cycle lubrication system;
  - ◆ FDI (frequency drive inverter);
  - ◆ PLC system;
  - ◆ Optional components: output shaft, air cushion, slide knock-out device, automatic feeder, etc.

### 技术参数 Specifications

名称 Items		技术参数 Technical Data	型号 Model	YS1-80	YS1-125	YS1-160	YS1-200	YS1-250	YS1Z-315	YS1Z-400	YS1Z-500	YS1Z-630	YS1Z-800
公称力 Nominal Pressure		KN		800	1250	1600	2000	2500	3150	4000	5000	6300	8000
公称行程 Nominal Pressure Stroke		mm		4	5	6	6	7	8	8	10	13	13
滑块行程 Stroke of Slide		mm		140	160	180	200	220	200	200	200	200	200
行程次数 Stroke		S.P.M		40~75	45~65	35~55	30~50	30~45	25~40	25~35	20~30	15~20	10~15
最大装模高度 Max. Die Set Height		mm		320	370	400	450	500	550	550	550	550	600
装模高度调节量 Die Height Adjustment		mm		80	90	100	110	110	120	120	120	120	120
立柱间距离 Distance Between Uprights		mm		840	1040	1140	1240	1340	1440	1440	1540	1850	2120
侧面开孔(前-后) Dimension of Side Hole (F-B)		mm		500	600	600	650	700	750	800	900	1000	1000
滑块底面 Bottom Size of Slide	左右 L-R	mm		780	980	1080	1180	1280	1380	1380	1450	1600	1700
	前后 F-B	mm		500	600	600	650	700	750	800	800	1200	1200
模柄孔 Hole for Punch Shank	直径 Diameter	mm		Φ50	Φ60	Φ70	Φ70	Φ70	Φ70	Φ70	Φ70	Φ70	Φ70
	深度 Depth	mm		60	80	80	80	80	80	80	100	100	100
工作台板 Size of Table	左右 L-R	mm		800	1000	1100	1200	1300	1400	1400	1500	1700	1800
	前后 F-B	mm		550	630	650	800	900	900	1000	1000	1300	1300
台板落料孔 Size Opening in the Table		mm		Φ150	Φ160	Φ180	Φ200	Φ250	Φ250	Φ250	Φ250	Φ250	Φ250
主电机功率 Main Motor Power		KW		7.5	15	15	22	30	37	37	55	75	75

注：根据客户工艺可定制行程可调压力机YS1A型、快速回程压力机YS1L型。

### 机床外形尺寸图 Outline Size Diagram

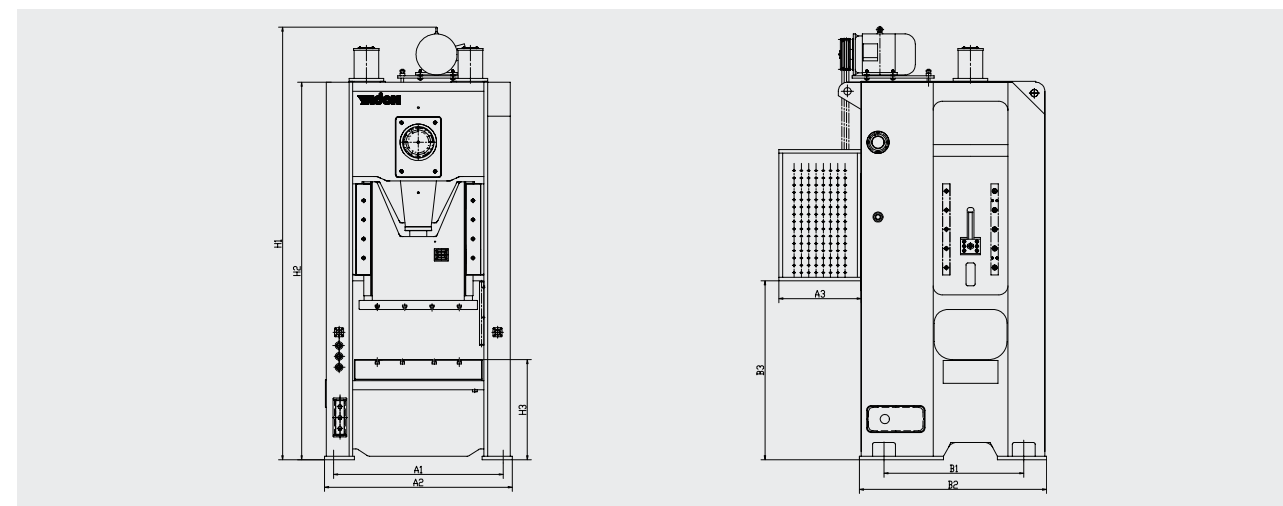

### 机床外形尺寸参数 Parameters of Outline Size

型号参数 Module	YS1-80	YS1-125	YS1-160	YS1-200	YS1-250	YS1Z-315	YS1Z-400	YS1Z-500	YS1Z-630	YS1Z-800
地脚螺栓尺寸A1×B1 Anchor Bolt Size A1×B1	1200×855	1410×980	1500×1030	1600×1175	1640×1120	1820×1575	1860×1535	1880×1785	2360×1850	2680×(1130+950)
安装尺寸A2×B2 Install Size A2×B2	1340×1155	1540×1360	1660×1430	1780×1595	1860×1570	2000×1990	2060×2055	2180×2220	2640×2440	2980×2605
最大尺寸A3×B3 Max Size A3×B3	600×1500	600×1675	720×1720	750×1855	850×1965	850×1980	900×1965	1005×2300	1085×2480	1084×2500
操作台高度H3 Table Height H3	815	900	980	1025	1025	1050	1100	1230	1370	1390
机身高度H2 Frame Height H2	2685	3025	3230	3665	3810	4050	4145	4890	5365	5705
总高度H1 Table Height H1	3090	3490	3695	4170	4365	4660	4750	5500	6365	6580

### 滑块底面 Slide Bottom

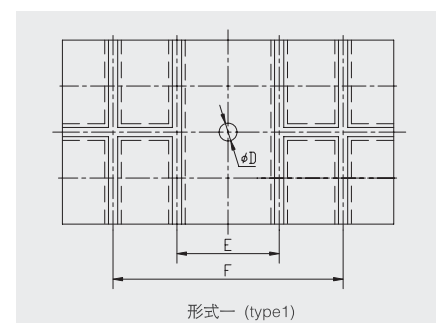

### 工作台板 Working Table

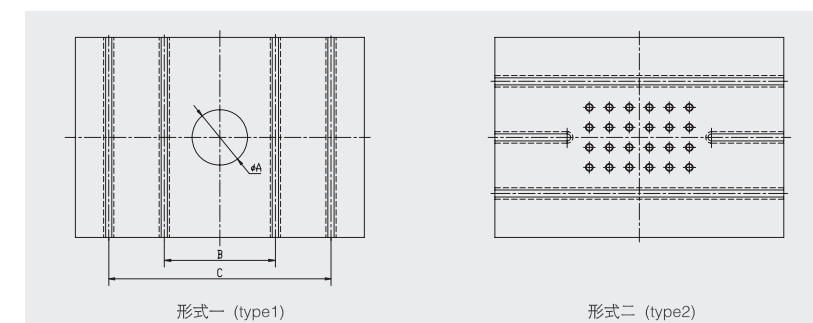

Model	YS1-80	YS1-125	YS1-160	YS1-200	YS1-250	YS1Z-315	YS1Z-400	YS1Z-500	YS1Z-630	YS1Z-800
ΦA	150	160	180	200	250	250	250	250	250	250
B	360	300	400	450	500	550	550	600	700	750
C	-	700	800	900	1000	900	900	1000	1000	1000
ΦD	50	60	70	70	70	70	70	70	70	70
E	200	200	260	350	400	400	300	360	450	400
F	-	-	680	800	800	900	900	1000	1000	1000
T型槽 T-Groove	I	II	II	II	II	II	II	II	II	II

### T型槽 T Groove

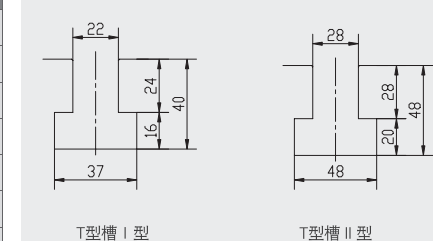



# JB36 闭式双点压力机

## Straight Side Double Crank Press



### 主要功能和特点 Main Structure Features

- ◆ 合金钢双曲轴逆向运转，抵消侧向力；
  - ◆ 左右抗偏心负荷强；
  - ◆ 高精度，满足JIS1级标准；
  - ◆ 闭式高刚性焊接机身；
  - ◆ 高精度八面长导轨（110T、160T为六面导向）；
  - ◆ 气动摩擦离合器；
  - ◆ 进口安全双联电磁阀；
  - ◆ 高灵敏度液压过载保护；
  - ◆ 变频调速；
  - ◆ PLC、编码器、机械凸轮控制；
  - ◆ 选配：输出轴、气垫、滑块打料、自动送料等装置。
- ◆ Alloyed steel double crank with reverse running, counteract the side force;
  - ◆ High off-set load capability in L-R direction;
  - ◆ High accuracy, reaches JIS1;
  - ◆ Straight side structure and High rigidity steel welded frame;
  - ◆ High precision, 8-side long guide rail (110T,160T 6-side long guide rail);
  - ◆ Pneumatic clutch-brake unit;
  - ◆ Imported safety dual-solenoid valve for clutch;
  - ◆ High sensitive HOLP;
  - ◆ FDI (frequency drive inverter);
  - ◆ PLC、encoder、cam controller;
  - ◆ Optional components: output shaft, air cushion, slide knockout device, automatic feeder, etc.

### 技术参数 Specifications

名称 Items	技术参数 Technical Data	型号 Model	JB36-110 JB36-160 JB36-200 JB36-250 JB36-315 JB36-400 JB36-500 JB36-630 JB36-800											
			JB36-110	JB36-160	JB36-200	JB36-250	JB36-315	JB36-400	JB36-500	JB36-630	JB36-800			
公称力 Nominal Pressure	KN		1100	1600	2000	2500	3150	4000	5000	6300	8000			
公称力行程 Nominal Pressure Stroke	mm		5 3	6 3	7 4	7 4	8	8	10	10	10			
滑块行程 Stroke of Slide	mm		180 110	200 130	230 150	250 180	250	250	280	300	300			
行程次数 Stroke	S.P.M		35~65 45~80	30~50 35~65	25~45 30~55	20~40 30~50	20~35	20~35	18~25	15~25	15~25			
最大装模高度 Max.Die Set Height	mm		400 435	450 485	500 540	550 585	550	550	580	600	600			
装模高度调节量 Die Height Adjustment	mm		90	100	110	120	120	120	120	120	120			
立柱间距离 Distance Between Uprights	mm		1750	1970	2220	2400	2600	2750	2900	3100	3500			
滑块底面 Bottom Size of Slide	左右 L-R	mm	1360	1500	1850	2000	2100	2300	2400	2600	3000			
	前后 F-B	mm	520	580	650	700	750	800	850	1100	1200			
工作台板 Size of Table	左右 L-R	mm	1700	1930	2100	2300	2400	2700	2850	3000	3200			
	前后 F-B	mm	680	760	840	920	950	1000	1200	1400	1400			
侧面开口 L-Side Openings	上下 Up and Down	mm	500	500	600	600	600	600	600	600	700			
	前后 F-B	mm	600	750	800	900	900	900	1000	1000	1000			
主电机功率 Main Motor Power	KW		15	22	22	30	37	37	45	55	75			

### 机床外形尺寸图 Outline Size Diagram

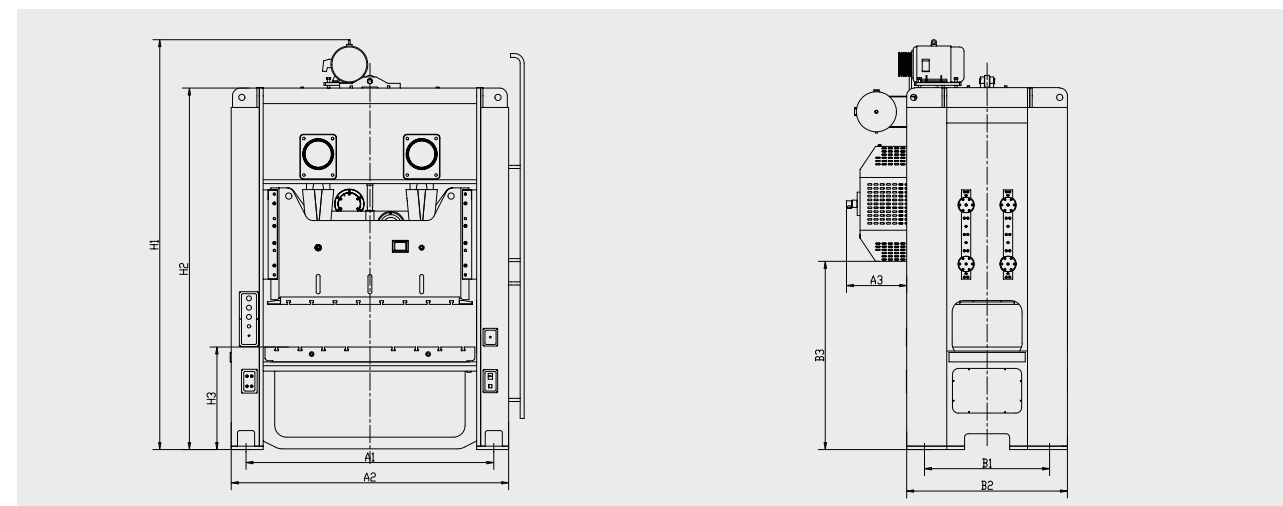

### 机床外形尺寸参数 Parameters of Outline Size

型号参数 Model	JB36-110	JB36-160	JB36-200	JB36-250	JB36-315	JB36-400	JB36-500	JB36-630	JB36-800
地脚螺栓尺寸A1 x B1 Anchor Bolt Size A1 x B1	2030X960	2270X1090	2540X1160	2780X1320	2960X1390	3190X1610	3300X1560	3530X1660	3970X1735
安装尺寸A2 x B2 Install Size A2 x B2	2330X1300	2560X1510	2820X1600	3120X1760	3320X1850	3570X2270	3740X2100	4000X2260	4440X2335
最大尺寸A3 x B3 Max Size A3 x B3	600X1600	800X1700	820X1850	720X2050	750X2190	800X2270	1400X2870	1600X3070	1620X3600
操作台高度H3 Table Height H3	895	960	1080	1190	1320	1320	1350	1550	1610
机身高度H2 Frame Height H2	3020	3320	3760	4030	4290	4510	4830	5210	5790
总高度H1 Table Height H1	3550	3870	4370	4640	4950	5260	5510	6400	6690

### 滑块底面 Slide Bottom

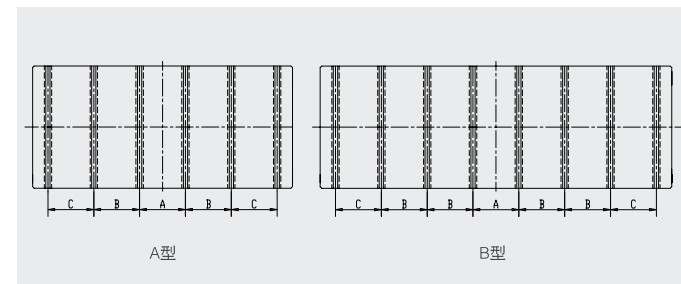

### 工作台板 Working Table

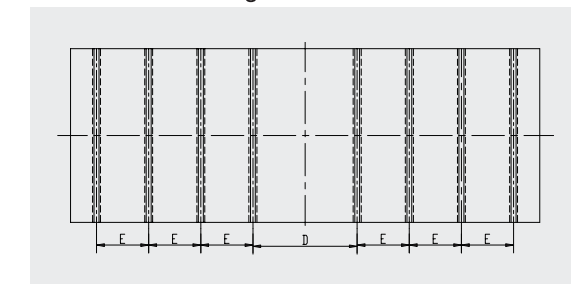

型号 Model	JB36-110	JB36-160	JB36-200	JB36-250	JB36-315	JB36-400	JB36-500	JB36-630	JB36-800
A	200	250	250	250	300	300	300	600	600
B	200	250	250	250	300	300	300	300	300
C	200	250	200	250	200	300	300	300	300
D	300	400	350	500	600	600	600	600	600
E	200	200	250	250	300	300	300	300	300
滑块底面 Slide Bottom	A型	A型	B型	B型	B型	B型	B型	B型	B型

### T型槽 T Groove

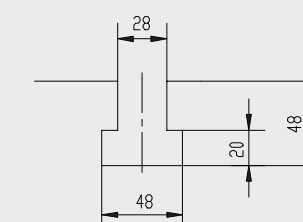



# YCM 闭式双点压力机

## Straight Side Double Crank Press



### 主要功能和特点 Main Structure Features

- ◆ 高刚性机身，满足JIS1级标准，机身变形量小，模具使用寿命大幅提升；
  - ◆ 低噪音、低振动、下料剪段噪音小；
  - ◆ 左右偏心负荷强；
  - ◆ 固锁式六面长导路，精度高；
  - ◆ 多功能微电脑电控系统。
- ◆ High rigidity frame with less deflection, reach JIS1; greatly improving tools service life;
  - ◆ Low noise, low vibration;
  - ◆ Good resistant capacity for offset load to the slide;
  - ◆ 6-face long guiding gibs, ensuring high precision;
  - ◆ Multi-function Micro-computer control system.

### 技术参数 Specifications

名称 Items	技术参数 Technical Data	型号 Model	YCM-110		YCM-160		YCM-200		YCM-250		YCM-300		YCM-400		YCM-500
			V	H	V	H	V	H	V	H	V	H	V	V	
公称力 Nominal Pressure	KN		1100		1600		2000		2500		3000		4000		5000
公称行程 Nominal Pressure Stroke	mm		5	3	6	3	6	3	7	3	7	3	7	7	8
滑块行程 Stroke of Slide	mm		180	110	180	130	230	150	250	170	250	170	250	250	280
行程次数 Stroke	S.P.M		35~65	50~100	30~55	40~85	20~50	35~70	20~40	30~60	20~35	30~50	20~30	20~30	18~25
最大装模高度 Max. Die Set Height	mm		400	350	450	400	500	450	550	450	550	450	550	550	600
装模高度调节量 Die Height Adjustment	mm		100		100		120		120		120		120		150
滑块底面 Bottom Size of Slide	mm		1360 × 520 × 70		1600 × 650 × 70		1850 × 750 × 95		2300 × 900 × 85		2400 × 900 × 95		2700 × 1000 × 95		2700 × 1100 × 110
工作台板 Size of Table	mm		1600 × 650 × 130		1800 × 760 × 150		2200 × 940 × 170		2500 × 1000 × 170		2500 × 1000 × 190		2800 × 1100 × 190		2800 × 1200 × 220
侧面开口 L-Side Openings	mm		650 × 400		700 × 450		900 × 600		900 × 600		900 × 600		900 × 600		1000 × 600
主电机功率 Main Motor Power	Kw × P		11 × 4		15 × 4		18.5 × 4		22 × 4		30 × 4		37 × 4		45 × 4
滑块调整机构 Slide Adjust Device	Kw × P		0.75 × 4		1.1 × 4		1.5 × 4		1.5 × 4		1.5 × 4		2.2 × 4		5 × 4

### 机床外形尺寸图 Outline Size Diagram

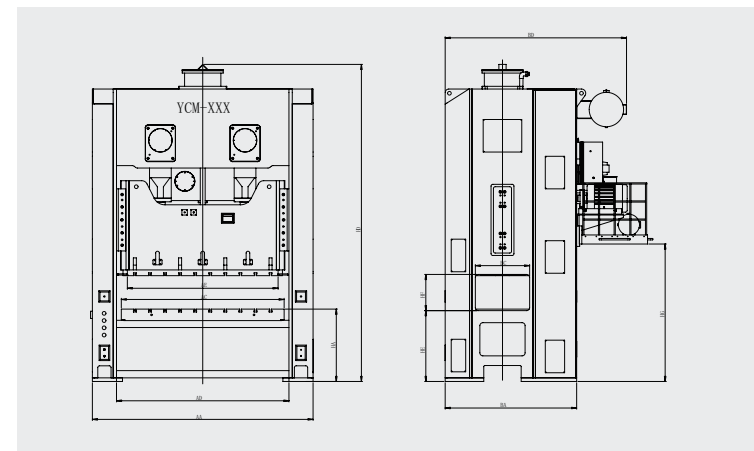

### 工作台板 Working Table

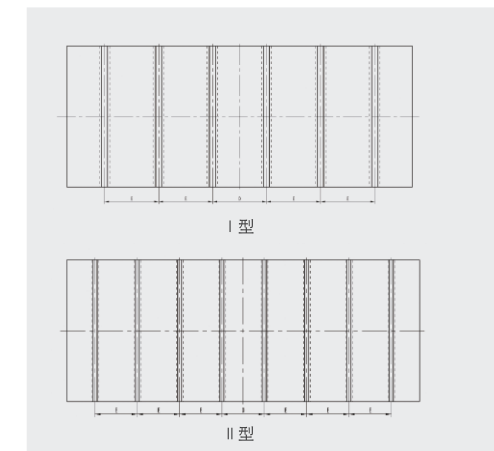

### 机床外形尺寸参数 Parameters of Outline Size

型号参数 Model	YCM-110		YCM-160		YCM-200		YCM-250		YCM-300		YCM-400		YCM-500	
	V	H	V	H	V	H	V	H	V	H	V	V	V	
AA	2320		2530		2920		3540		3542		3850		3910	
AC	1600		1800		2200		2500		2500		2800		2800	
AD	1662		1880		2270		2740		2742		3050		3050	
AE	1360		1600		1850		2300		2400		2700		2700	
BA	1340		1505		1800		1740		1745		2160		2330	
BC	650		700		900		900		900		900		1000	
BD	1930		2130		2330		2480		2490		3020		3220	
HA	850		1000		1100		1100		1200		1200		1300	
HD	3180	3093	3730	3699	3990	3903	4450	4274	4880	4832	5200		5770	
HE	830		980		1060		1060		1210		1180		1270	
HF	400		450		600		600		600		600		600	
HG	-	-	1670	1795	1840	1916	2100	2027	2120	2195	2220		2540	

### 滑块底面 Slide Bottom

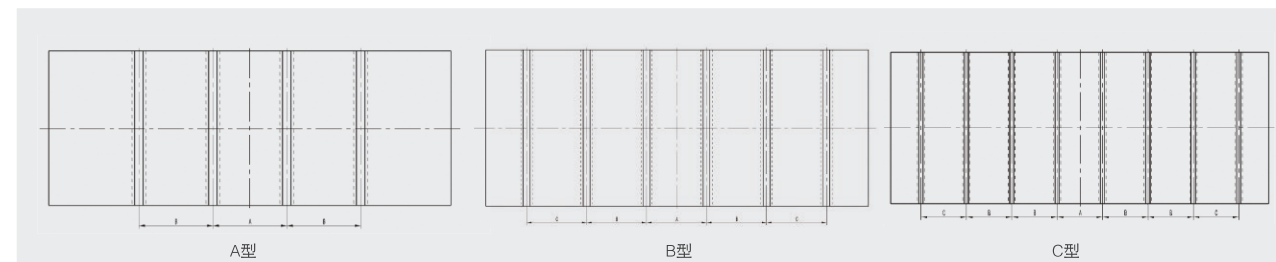

型号 Model	YCM-110	YCM-160	YCM-200	YCM-250	YCM-300	YCM-400	YCM-500
A	250	250	250	300	300	300	300
B	250	250	250	300	300	300	300
C	-	250	250	300	300	300	300
D	250	250	250	300	300	300	300
E	250	250	250	300	300	300	300
滑块底面 Slide bottom	A型	B型	B型	C型	C型	C型	C型
台板台面 Working Table	I型	I型	II型	II型	II型	II型	II型

### T型槽 T Groove

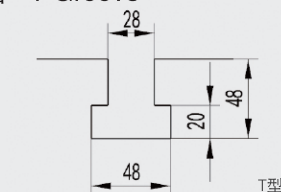



# JY21 半闭式固定台高性能压力机

## Semi-closed Type Fixed Table Press



### 主要功能和特点 Main Structure Features

- ◆ 高精度，满足JIS1级标准；
  - ◆ 半闭式高刚性焊接机身；
  - ◆ 高精度八面长导轨；
  - ◆ 干式气动摩擦离合器；
  - ◆ 进口安全双联电磁阀；
  - ◆ 高灵敏度液压过载保护；
  - ◆ 稀油自动润滑；
  - ◆ 变频调速；
  - ◆ PLC集中控制，操作便利；
  - ◆ 选配：输出轴、气垫、滑块打料、自动送料等装置。
- ◆ High accuracy, reaches JIS1;
  - ◆ Semi-closed structure and High rigidity steel welded frame;
  - ◆ High precision, 8-side long guide rail;
  - ◆ Dry type pneumatic clutch-brake unit;
  - ◆ Imported safety dual-solenoid valve for clutch;
  - ◆ High sensitive HOLP;
  - ◆ Automatic oil cycle lubrication system;
  - ◆ FDI (frequency drive inverter);
  - ◆ PLC system;
  - ◆ Optional components: output shaft, air cushion, slide knockout device, automatic feeder, etc.

### 技术参数 Specifications

名称 Items	技术参数 Technical Data	型号 Model	JY21-45	JY21-63	JY21-100	JY21-160	JY21-200	JY21-250	JY21-315	JY21-400
公称力 Nominal Pressure	KN		450	630	1000	1600	2000	2500	3150	4000
公称行程 Nominal Pressure Stroke	mm		3.2	4	5	6	6	7	8	8
滑块行程 Stroke of Slide	mm		100	120	160	180	200	220	250	250
行程次数 Stroke	S.P.M		60~90	50~80	35~70	30~55	25~50	25~45	25~40	25~35
最大装模高度 Max. Die Set Height	mm		270	300	350	400	450	500	550	550
装模高度调节量 Die Height Adjustment	mm		60	80	90	100	110	110	120	120
立柱间距离 Distance Between Uprights	mm		540	630	920	980	1100	1100	1170	1170
侧面开孔(前-后) Dimension of Side Hole (F-B)	mm		470	520	650	680	860	860	860	880
滑块底面 Bottom Size of Slide	左右 L-R	mm	500	600	800	880	950	950	1100	1100
	前后 F-B	mm	300	350	460	480	570	620	720	720
模柄孔 Hole for Punch Shank	直径 Diameter	mm	Φ50	Φ50	Φ60	Φ70	Φ70	Φ70	Φ70	Φ70
	深度 Depth	mm	60	60	80	80	80	90	100	100
工作台板 Size of Table	左右 L-R	mm	800	850	1000	1200	1350	1400	1500	1600
	前后 F-B	mm	450	500	630	650	800	800	840	860
工作台落料孔 Table Blanking Hole	mm	Φ150	Φ150	Φ160	Φ180	Φ200	Φ250	Φ250	Φ250	Φ250
主电机功率 Main Motor Power	KW		5.5	7.5	11	15	22	30	37	37

### 机床外形尺寸图 Outline Size Diagram

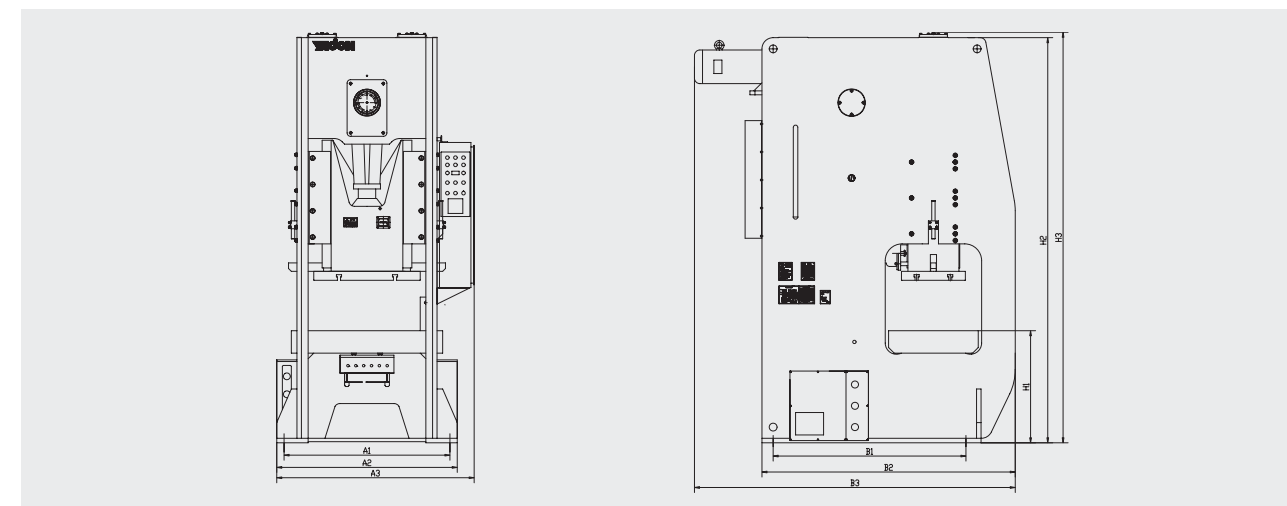

### 机床外形尺寸参数 Parameters of Outline Size

型号参数 Module	JY21-45	JY21-63	JY21-100	JY21-160	JY21-200	JY21-250	JY21-315	JY21-400
地脚螺栓尺寸A1 x B1 Anchor Bolt Size A1 x B1	890 x 950	980 x 1100	1260 x 1450	1340 x 1640	1480 x 1720	1500 x 1840	1580 x (1100+1100)	1600 x (1200+1275)
安装尺寸A2 x B2 Install Size A2 x B2	1000 x 1355	1160 x 1610	1440 x 1975	1520 x 2085	1660 x 2260	1680 x 2400	1770 x 2750	1790 x 2850
最大尺寸A3 x B3 Max Size A3 x B3	1110 x 1770	1235 x 1910	1510 x 2210	1590 x 2470	1730 x 2685	1750 x 3260	1840 x 3495	1860 x 3530
操作台高度H1 Table Height H1	750	850	860	915	1000	1000	1050	1050
机身高度H2 Frame Height H2	2200	2510	2915	3165	3615	3710	4030	4075
总高度H3 Table Height H3	2565	2890	3065	3365	3665	4050	4315	4395

### 滑块底面 Slide Bottom

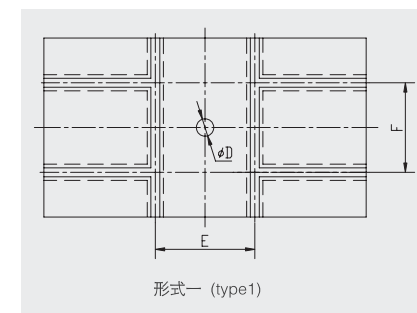

### 工作台板 Working Table

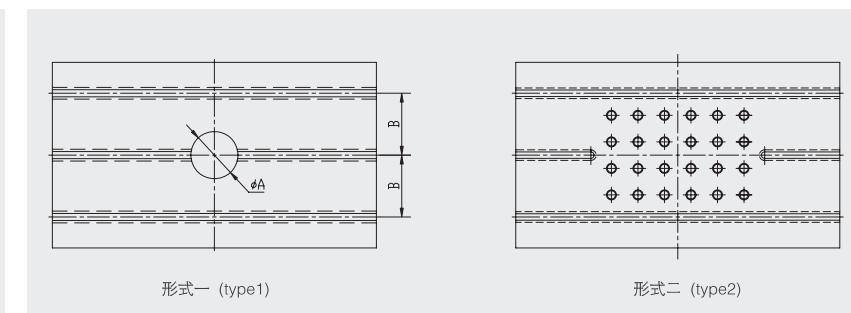

Model	JY21-45	JY21-63	JY21-100	JY21-160	JY21-200	JY21-250	JY21-315	JY21-400
ΦA	150	150	160	180	200	250	250	250
B	120	340	450	500	650	670	700	900
ΦD	50	50	50	70	70	70	70	70
E	200	200	260	360	500	500	750	800
F	-	-	-	-	300	300	350	350
T型槽 T-Groove	I	I	I	II	II	II	II	II

### T型槽 T Groove

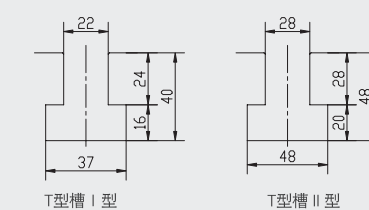



# J24 开式快速返程压力机

## C-type Frame Link Drive Press



### 主要功能和特点 Main Structure Features

- ◆ 多连杆传动，慢速加工和快速回程特性；
- ◆ 生产效率较之普通曲柄冲床提高约30%；
- ◆ 高精度，满足JIS1级标准；
- ◆ 高刚性焊接机身；
- ◆ 高精度六面长导轨；
- ◆ 干式气动摩擦离合器；
- ◆ 高灵敏度液压过载保护；
- ◆ 浓油自动润滑；
- ◆ 变频调速；
- ◆ PLC集中控制，操作便利；
- ◆ 选配：输出轴、气垫、滑块打料、自动送料等装置。
- ◆ Link motion drive, with slow down processing and quick return running;
- ◆ Production efficiency increases about 30% comparing with normal press;
- ◆ High accuracy, reach JIS1;
- ◆ High rigidity, steel-welded frame;
- ◆ High precision, 6-side long guide rail;
- ◆ Dry type pneumatic clutch-brake unit;
- ◆ High sensitive HOLP;
- ◆ Automatic grease lubrication system;
- ◆ FDI ( frequency drive inverter ) ;
- ◆ PLC system;
- ◆ Optional components: output shaft, air cushion, slide knockout device, automatic feeder, etc.

### 技术参数 Specifications

名称 Items		技术参数 Technical Data	型号 Model	J24-110	J24-160	J24-200	J24-250
公称力 Nominal Pressure		KN		1100	1600	2000	2500
公称力行程 Nominal Pressure Stroke		mm		5	6	6	7
滑块行程 Stroke of Slide		mm		160	180	200	220
行程次数 Stroke		S.P.M		35~70	30~55	25~50	25~45
最大装模高度 Max.Die Set Height		mm		350	400	450	500
装模高度调节量 Die Height Adjustment		mm		90	100	110	110
喉口深度 Depth of Throat		mm		350	390	420	430
立柱间距离 Distance Between Uprights		mm		680	720	830	850
滑块底面 Bottom Size of Slide	左右 L-R	mm		620	700	850	880
	前后 F-B	mm		520	580	650	700
模柄孔 Hole for Punch Shank	直径 Diameter	mm		Φ70	Φ70	Φ70	Φ70
	深度 Depth	mm		80	100	100	100
工作台板 Size of Table	左右 L-R	mm		1100	1260	1400	1500
	前后 F-B	mm		680	760	820	840
电机功率 Main Motor Power		KW		11	15	22	30
冲床外形 Overall Dimensions	左右 L-R	mm		1419	1570	1630	1750
	前后 F-B	mm		2200	2380	2690	2830
	高 Height	mm		3190	3375	3810	3930

# JB36L 闭式双点快速返程压力机

## Straight Double-crank Frame Link Drive Press



### 主要功能和特点 Main Structure Features

- ◆ 多连杆传动，慢速加工和快速回程特性；
- ◆ 生产效率较之普通曲柄冲床提高约30%；
- ◆ 高精度，满足JIS1级标准；
- ◆ 高刚性焊接机身；
- ◆ 高精度八面长导轨（110T、160T为六面导向）；
- ◆ 干式气动摩擦离合器；
- ◆ 高灵敏度液压过载保护；
- ◆ 浓油自动润滑；
- ◆ 变频调速；
- ◆ PLC集中控制，操作便利；
- ◆ 选配：输出轴、气垫、滑块打料、自动送料等装置。
- ◆ Link motion drive, with slow down processing and quick return running;
- ◆ Production efficiency increases about 30% comparing with normal press;
- ◆ High accuracy, reach JIS1;
- ◆ High rigidity, steel-welded frame;
- ◆ High precision, 8-side long guide rail (110T, 160T 6-side long guide rail);
- ◆ Dry type pneumatic clutch-brake unit;
- ◆ High sensitive HOLP;
- ◆ Automatic grease lubrication system;
- ◆ FDI (frequency drive inverter);
- ◆ PLC system;
- ◆ Optional components: output shaft, air cushion, slide knockout device, automatic feeder, etc.

### 技术参数 Specifications

名称 Items		技术参数 Technical Data	型号 Model	JB36L-110	JB36L-160	JB36L-200	JB36L-250	JB36L-315	JB36L-400	JB36L-500	JB36L-630
公称力 Nominal Pressure		KN		1100	1600	2000	2500	3150	4000	5000	6300
公称力行程 Nominal Pressure Stroke		mm		5	3	6	3	7	4	7	4
行程次数 Stroke		S.P.M		35~65	45~80	30~50	35~65	25~45	30~55	20~40	30~50
最大装模高度 Max.Die Set Height		mm		400	435	450	485	500	540	550	585
装模高度调节量 Die Height Adjustment		mm		90	100	110	120	120	120	120	120
立柱间距离 Distance Between Uprights		mm		1750	1970	2220	2400	2600	2750	2900	3100
滑块底面 Bottom Size of Slide	左右 L-R	mm		1360	1500	1850	2000	2100	2300	2400	2600
	前后 F-B	mm		520	580	650	700	750	800	850	1100
工作台板 Size of Table	左右 L-R	mm		1700	1930	2100	2300	2400	2700	2850	3000
	前后 F-B	mm		680	760	840	920	950	1000	1200	1400
侧面开口 L-Side Openings	上下 Up and Down	mm		500	500	600	600	600	600	700	700
	前后 F-B	mm		600	750	800	900	900	900	1000	1000
冲床外形 Overall Dimensions	左右 L-R	mm		2350	2600	3050	3350	3550	3800	3950	4000
	前后 F-B	mm		1950	2370	2500	2650	2700	2800	3600	3900
	高 Height	mm		3530	3900	4400	4900	5200	5300	5750	6100
主电机功率 Main Motor Power		KW		15	22	22	30	37	37	45	55



# YSH 闭式三点 / 四点高速精密冲压线

## NC High-speed Three/Four-point Press Line

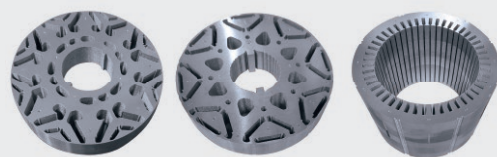

### 主要功能和特点 Main Structure Features

- ◆ 机床超过JIS-B-6402特级精度;
  - ◆ 三点式驱动长滑块, 400XL/400XXL四点式;
  - ◆ 分体高强铸铁机身;
  - ◆ 四柱高刚性圆柱直线轴承导向;
  - ◆ 动平衡系统, 低振动、低噪音;
  - ◆ 调节螺杆液压锁紧, 确保下死点精度;
  - ◆ 装模高度调整精度0.01mm;
  - ◆ 强制润滑、温度自控系统、热补偿技术精准控制下死点精度;
  - ◆ 一体化触摸屏操控介面。
- ◆ Precision exceed JIS-B-6402 special-grade;
  - ◆ Three-point drive, long guiding slide, (400XL/400XXL model is 4-point drive)
  - ◆ Main press body adopts 2 separated parts structure, cast-iron frame, (400XL/400XXL model is 3 parts design);
  - ◆ 4-column adopt high-rigidity linear bearings for guiding;
  - ◆ Adopts dynamic balance system, ensure low vibration and low noise;
  - ◆ Adopts hydraulic locking device for screw adjustment, ensure the precision of bottom dead center;
  - ◆ Die height adjustment precision reaches 0.01mm;
  - ◆ Adopts forced lubrication system, automatic temperature control system and use thermal compensation technology to ensure the precision of bottom dead center;
  - ◆ Touch screen control.

机床外形尺寸图 Outline Size Diagram

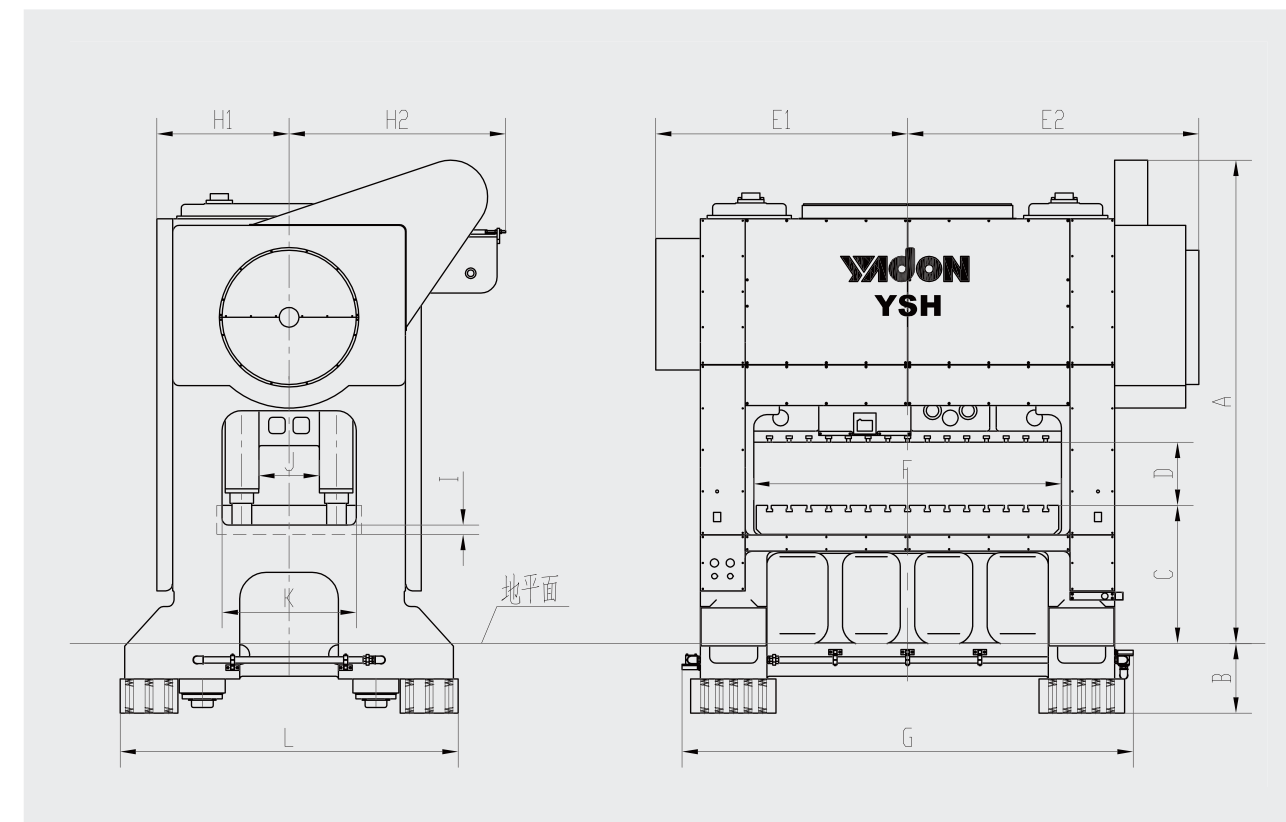

### 技术参数 Specifications

名称 Items	技术参数 Technical Data		型号 Model						
			YSH-220	YSH-300	YSH-300L	YSH-400	YSH-400L	YSH-400XL	YSH-400XXL
公称力 Nominal Pressure	KN		2200	3000	3000	4000	4000	4000	4000
公称力行程 Nominal Pressure Stroke	mm		3	3	3	3	3	3	3
滑块行程 Stroke of Slide	mm		30	30	30	35	35	35	50
行程次数 Stroke	S.P.M		120~420	110~400	110~350	100~300	100~280	100~260	90~200
最大装模高度 Max.Die Set Height	mm		450	500	550	550	600	600	620
装模高度调节量 Die Height Adjustment	mm		50	50	60	60	80	80	80
立柱间距离 Distance Between Uprights	左右 L-R	mm	2040	2340	2740	2840	3340	3740	4240
	前后 F-B	mm	400	460	460	560	560	560	560
滑块底面 Bottom Size of Slide	左右 L-R	mm	2000	2300	2700	2800	3300	3700	4200
	前后 F-B	mm	700	800	800	1000	1000	1100	1100
工作台板 Size of Table	左右 L-R	mm	2000	2300	2700	2800	3300	3700	4200
	前后 F-B	mm	950	1000	1000	1200	1200	1200	1200
主电机功率 Main Motor Power	KW		45	55	55	75	75	75	75

### 机床外形尺寸参数 Parameters of Outline Size

型号参数 Model			YSH-220	YSH-300	YSH-300L	YSH-400	YSH-400L	YSH-400XL	YSH-400XXL
A	地面上高度	mm	3550	3800	4000	4400	4700	5000	5200
B	地面下高度	mm	350	550	600	1090	1170	1250	1250
C	工作高度	mm	1050	1050	1050	1050	1050	1050	1050
D	装模范围	mm	400~450	450~500	490~550	490~550	470~550	520~600	540~620
E1	上部左右长度	mm	1700	1950	2150	2250	2500	2700	2950
E2	上部左右长度	mm	2100	2350	2550	2700	2950	2700	2950
F	左右立柱间距	mm	2040	2340	2740	2840	3340	3740	4240
G	下部左右长度	mm	3050	3450	3850	4050	4550	5000	5500
H1	上部前后长度	mm	880	1000	1000	1170	1170	1200	1200
H2	上部前后长度	mm	1500	1650	1650	1900	1900	1200	1200
I	送料定位高度	mm	70	70	70	90	90	90	90
J	前后立柱间距	mm	400	460	460	560	560	560	560
K	前后立柱窗宽度	mm	870	1020	1020	1200	1200	1250	1250
L	下部前后长度	mm	2100	2600	2600	2900	2900	2900	2900



# J76 闭式双点高速精密冲压线

## Straight Side High-speed Two-point Precision Press Line



### 主要功能和特点 Main Structure Features

- ◆ 80-400T 两段分体组合式高强铸铁机身，550-750T为三段分体式；
- ◆ 偏心式高强合金钢曲轴；
- ◆ 进口轴承四点式曲轴支撑（80-400T）；
- ◆ 滑块无间隙大承载滚珠导柱导套结构（80-400T）；
- ◆ 动平衡系统，低振动、低噪音；
- ◆ 低惯量大扭矩气动离合器制动器；
- ◆ 调节螺杆液压锁紧，确保下死点精度；
- ◆ 强制润滑、温度自控系统、热补偿技术精准控制下死点精度；
- ◆ 可编程凸轮控制器；
- ◆ 一体化触摸屏操控介面。
- ◆ Separated structure and High rigidity cast-iron frame;
- ◆ High strength eccentric alloyed steel crank;
- ◆ Imported bearings and four-point crank supporting structure (80-400T) ;
- ◆ Slide is guided by linear clearance-free ball bearing plunger bushes.;
- ◆ Low vibration and low noise;
- ◆ Big torque, low inertia, pneumatic clutch-brake unit;
- ◆ Hydraulic locking device for adjustment rods, ensuring the precision of Bottom dead center;
- ◆ Forced lubrication system, Automatic temperature control system and using the thermal compensation technology to control the position of Bottom dead center in High precision;
- ◆ Programmable cam controller;
- ◆ Touch screen.



机床外形尺寸图 Outline Size Diagram

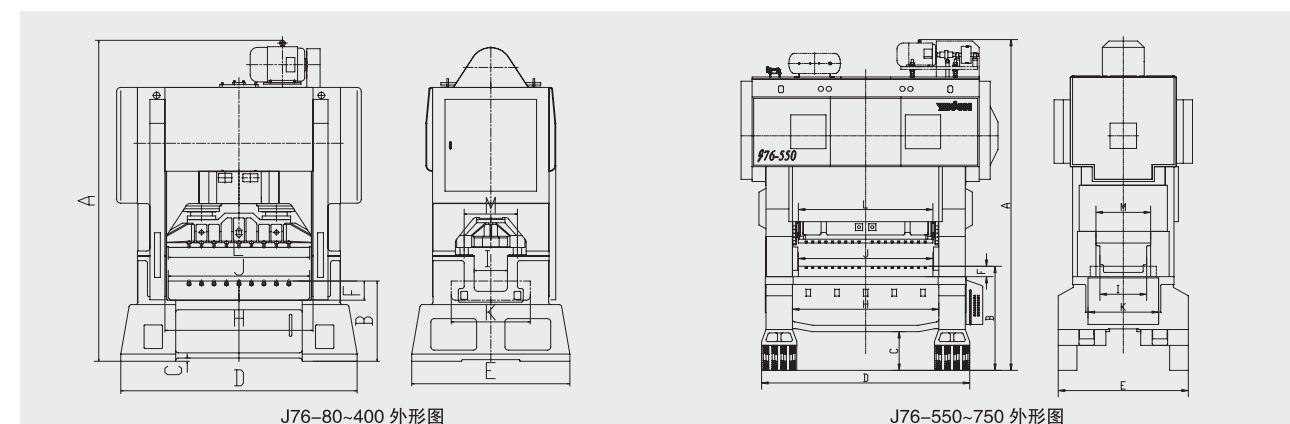

机床外形尺寸参数 Parameters of Outline Size

名称 Items	技术参数 Technical Data	型号 Model	J76-80	J76-125E	J76-200E	J76-220	J76-300E	J76-300L	J76-350	J76-400	J76-550	J76-750 (焊接机身)
公称力 Nominal Pressure	KN		800	1250	2000	2200	3000	3000	3500	4000	5500	7500
公称力行程 Nominal Pressure Stroke	mm		2	3	3	3	3	3	3	3	1.6	1.6
滑块行程 Stroke of Slide	mm		30	30	30	30	30	30	30	30	40	45
行程次数 Stroke	S.P.M		140~550	130~400	120~400	120~400	110~350	110~350	110~350	110~280	80~200	75~160
最大装模高度 Max.Die Set Height	mm		380	400	420	420	480	500	520	530	550	600
装模高度调节量 Die Height Adjustment	mm		50	50	50	50	50	50	50	50	100	100
立柱间距离 Distance Between Uprights	左右 L-R	mm	1140	1340	1740	1940	2140	2340	2440	2820	3080	3350
	前后 F-B	mm	320	400	400	420	470	470	470	580	1050	1000
滑块底面 Bottom Size of Slide	左右 L-R	mm	1100	1300	1700	1900	2100	2300	2400	2800	3050	3300
	前后 F-B	mm	500	600	650	700	750	750	900	1000	1400	1400
工作台板 Size of Table	左右 L-R	mm	1100	1300	1700	1900	2100	2300	2400	2800	3050	3300
	前后 F-B	mm	750	850	950	950	1000	1000	1000	1200	1500	1500
主电机功率 Main Motor Power	KW		22	22	37	37	45	45	55	75	75	90

### 技术参数 Specifications

名称 Items	技术参数 Technical Data	型号 Model	J76-80	J76-125E	J76-200E	J76-220	J76-300E	J76-300L	J76-350	J76-400	J76-550	J76-750 (焊接机身)
公称力 Nominal Pressure	KN		800	1250	2000	2200	3000	3000	3500	4000	5500	7500
公称力行程 Nominal Pressure Stroke	mm		2	3	3	3	3	3	3	3	1.6	1.6
滑块行程 Stroke of Slide	mm		30	30	30	30	30	30	30	30	40	45
行程次数 Stroke	S.P.M		140~550	130~400	120~400	120~400	110~350	110~350	110~350	110~280	80~200	75~160
最大装模高度 Max.Die Set Height	mm		380	400	420	420	480	500	520	530	550	600
装模高度调节量 Die Height Adjustment	mm		50	50	50	50	50	50	50	50	100	100
立柱间距离 Distance Between Uprights	左右 L-R	mm	1140	1340	1740	1940	2140	2340	2440	2820	3080	3350
	前后 F-B	mm	320	400	400	420	470	470	470	580	1050	1000
滑块底面 Bottom Size of Slide	左右 L-R	mm	1100	1300	1700	1900	2100	2300	2400	2800	3050	3300
	前后 F-B	mm	500	600	650	700	750	750	900	1000	1400	1400
工作台板 Size of Table	左右 L-R	mm	1100	1300	1700	1900	2100	2300	2400	2800	3050	3300
	前后 F-B	mm	750	850	950	950	1000	1000	1000	1200	1500	1500
主电机功率 Main Motor Power	KW		22	22	37	37	45	45	55	75	75	90



# YPH 大电机级进模冲压线

## Motor Lamination Production Line(Big-size Motor)



### 主要功能和特点 Main Structure Features

- ◆ 横梁、立柱、底座分体焊接机身；
  - ◆ 六点式高强度动压曲轴支撑；
  - ◆ 高强度单根双偏心轴，同步性好；
  - ◆ 高精度超长八面导向；
  - ◆ 连杆螺纹油压锁紧，确保下死点精度；
  - ◆ 液压过载保护装置；
  - ◆ 强制稀油自动润滑。
- ◆ H-type frame includes three parts: crossbeam, uprights and basement;
  - ◆ Six-point type crank supporting structure;
  - ◆ High strength double eccentric crank;
  - ◆ High precision, 8-side long guide rail;
  - ◆ Hydraulic locking device for adjustment rods, ensuring the precision of Bottom dead center;
  - ◆ High sensitive HOLP;
  - ◆ Automatic oil cycle lubrication system.

### 标准配置 Standard Accessories

- 主控电路及操作台 / Speration Console
  - 冲速显示器（电控集成）/ Speed Display
  - 计数器（电控集成）/ Counter
  - 计数器及批量设定 / Batch Setting
  - 触摸屏显示机床异常 / Touch Screen
  - 屏幕显示微电脑控制操作系统 / HMI
  - 电动式装模高度调整装置 / Motorsed Die Height Adjustment Device
  - 装模高度数字显示器 / Digital/Indicator of Die Height
  - 滑块气压平衡装置 / Balance Cylinder
- 组合式气动离合器 / Combined Pneumatic Clutch
  - 主电机正反转装置 / Motor Forth-reverse Device Inverter
  - 机床速度变频器调速 / Tixed Speed Motor
  - 循环油强制给油装置 / Circulating Lubrication System
  - 误送检知接口 / Mis-Feeder Detect
  - 压缩空气快速接头 / Compressed-air Quick Connector
  - 自动材料润滑装置 / Automatic Material Lubrication
  - 液压举模器 / Hydralic Lifting Arms
  - 移模臂 / Die Moving Arms

### 选择配置 Optional Accessories

- 夹模装置 / Die Clamping
- 精密齿轮送料机 / Precision Gear Feeding Machine
- 精密材料校平机 / Precision Leveling Machine
- 双头材料架 / Double-head Material Frame
- 链板式排屑器 / Chain-plate Chip Removal Device
- 扭槽控制器 / Skew Controller

### 技术参数 Specifications

名称 Items	技术参数 Technical Data	型号 Model	YPH-160	YPH-200	YPH-300	YPH-400	YPH-550	YPH-630	YPH-750
公称力 Nominal Pressure	KN		1600	2000	3000	4000	5500	6300	7500
公称力行程 Nominal Pressure Stroke	mm		3	3	3	3	2	2	2
滑块行程 Stroke of Slide	mm		30	30	30	40	50	50	50
行程次数 Stroke	S.P.M		100~250	100~250	90~200	80~180	80~160	80~140	70~120
最大装模高度 Max.Die Set Height	mm		400	450	500	550	550	600	600
装模高度调节量 Die Height Adjustment	mm		60	60	100	100	100	100	100
滑块底面(左右×前后) Bottom Size of Slide(L,R × F,B)	mm		1500 × 700	1800 × 700	2300 × 800	2700 × 1000	3000 × 1100	3200 × 1200	3300 × 1300
工作台板(左右×前后) Size of Table(L,R × F,B)	mm		1500 × 900	1800 × 950	2300 × 1000	2700 × 1200	3000 × 1300	3200 × 1300	3300 × 1400
侧面开口 Side Opening	mm		400	450	500	600	750	800	900
左右立柱间距 Left and Right Column Spacing	mm		1550	1850	2350	2750	3050	3250	3350
最大上模重量 The Maximum Weight of Upper Die	Kg		800	1100	1500	2000	2700	4000	4500
主电机功率 Main Motor Power	KW		30	37	45	55	75	75	90



# J31G 闭式单点高速压力机冲压线

## Straight Side High-speed One-point Press Line



### 主要功能和特点 Main Structure Features

- ◆ 生产效率与性价比高;
- ◆ 闭式箱体整体焊接机身;
- ◆ 滑块八面滚针导向;
- ◆ 组合式气动摩擦离合器;
- ◆ 连杆螺纹油压锁紧, 确保下死点精度;
- ◆ 液压过载保护装置;
- ◆ 浓油自动润滑。
- ◆ High production/cost efficiency;
- ◆ Closed type steel-welded frame;
- ◆ Slide is of 8-side pin guides;
- ◆ Pneumatic clutch and brake unit;
- ◆ Hydraulic locking device for adjustment rods, ensuring the precision of Bottom dead center;
- ◆ High sensitive HOLP;
- ◆ Automatic oil cycle lubrication system.

### 技术参数 Specifications

名称 Name	技术参数 Technical Data	型号 Model	J31G-80	J31G-80B	J31G-125	J31G-125B	J31G-160	J31G-160B	J31G-200	J31G-200B	J31G-300
公称力 Nominal Pressure	KN		800		1250		1600		2000		3000
公称力行程 Nominal Pressure Stroke	mm		2		3		3		3	2	3
滑块行程 Stroke of Slide	mm		30		30	40	30	40	30	20	30
行程次数 Stroke	S.P.M		160~280		160~240	150~220	160~220	130~200	150~200	100~180	100~150
最大装模高度 Max. Die Set Height	mm		360	370	400		400		400	420	450
装模高度调节量 Die Height Adjustment	mm		50		50		50	50	50		50
立柱间距离 Distance Between Uprights	左右 L-R	mm	920	1020	1120		1320		1320	1600	1420
	前后 F-B	mm	380	380	450		520		550	500	750
滑块底面 Bottom Size of Slide	左右 L-R	mm	800	1000	1000		1200		1200	1450	1300
	前后 F-B	mm	450	650	550	700	600		600	750	900
工作台板 Size of Table	左右 L-R	mm	900	1000	1100		1300		1300	1550	1400
	前后 F-B	mm	500	750	600	750	700	920	800	950	1000
工作台板孔 Size of Opening in Table	左右 L-R	mm	700	700	880		1000		1000	1300	620
	前后 F-B	mm	180	40	150		250		210	300	560
主电机功率 Main Motor Power	KW		11		18.5		22		30		37

注: J31G-B型为网板高速冲压线, 同时可增加行程可调节技术。

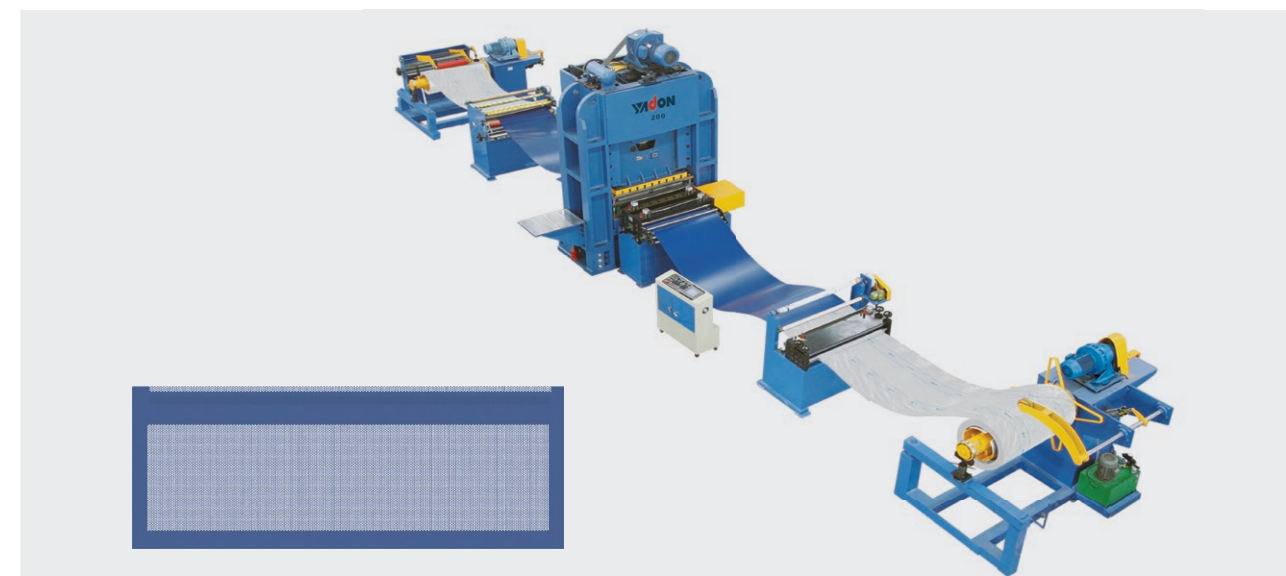

机床外形尺寸图 Outline Size Diagram

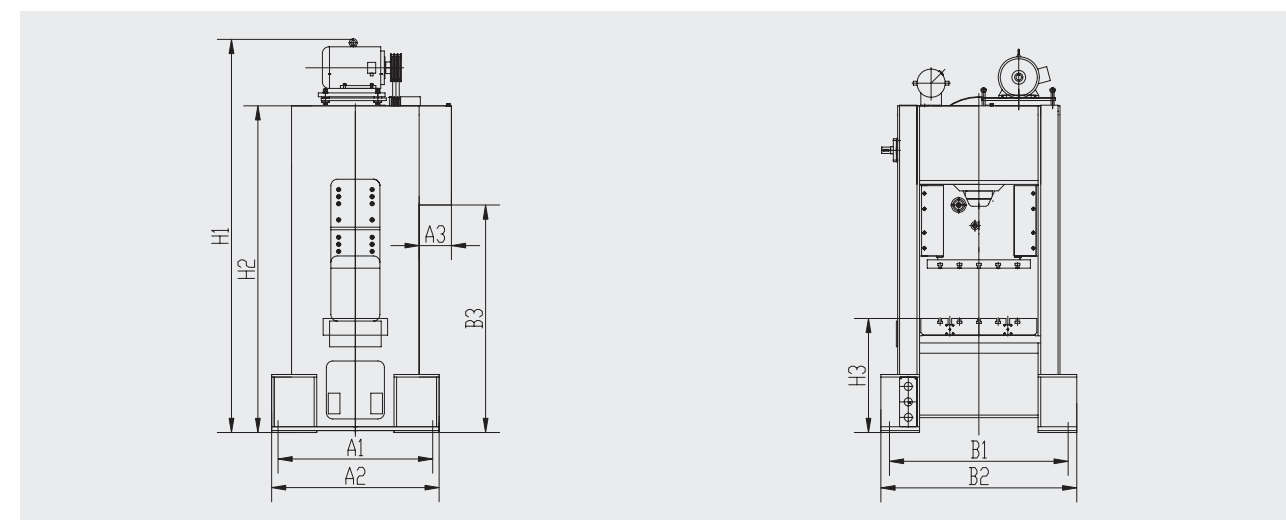

机床外形尺寸参数 Parameters of Outline Size

型号 Model	J31G-80	J31G-80B	J31G-125	J31G-125B	J31G-160	J31G-160B	J31G-200	J31G-200B	J31G-300
地脚螺栓尺寸 A1 × B1 Anchor Bolt Size A1 × B1	1390 × 900	1320 × 1050	1590 × 1080	1590 × 1080	1870 × 1180	1700 × 1100	2030 × 1300	1980 × 1125	2060 × 1260
机身安装尺寸 A2 × B2 Install Size A2 × B2	1520 × 1300	1620 × 1460	1680 × 1500	1680 × 1500	2020 × 1600	2020 × 1260	2400 × 1600	2560 × 1275	2720 × 1910
护罩支出尺寸 A3 × B3 Cover Size A3 × B3	250 × 1765	250 × 1730	280 × 1930	280 × 1930	300 × 1940	450 × 1910	520 × 2100	530 × 2240	600 × 2200
总高度 H1 Total Height H1	3140	3160	3430	3430	3840	3725	4210	4255	4710
机身高度 H2 Frame Height H2	2540	2550	2885	2885	3155	3155	3475	3520	3910
操作台高度 H3 Table Height H3	885	885	950	950	1010	1010	1050	1050	1050



# JL21G 开式高速压力机

## C-type Frame High-speed Press



### 主要功能和特点 Main Structure Features

- ◆ 钢板焊接机架，高强铸铁底座；
- ◆ 低振动、低噪音、高精度；
- ◆ 气囊平衡装置，平衡曲轴、滑块高速运转的振动；
- ◆ 连杆螺纹油压锁紧，确保下死点精度；
- ◆ 稀油自动润滑；
- ◆ PLC、编码器控制。
- ◆ Steel-welded frame and High rigidity cast-iron base;
- ◆ Low vibration, low noise and High accuracy;
- ◆ Air bag Balance device, to balance the crank and vibration during working;
- ◆ Hydraulic locking device for adjustment rods, ensuring the precision of Bottom dead center;
- ◆ Automatic oil cycle lubrication system;
- ◆ PLC, encoder.

### 技术参数 Specifications

名称 Items		技术参数 Technical Data	型号 Model	JL21G-16	JL21G-25	JL21G-45	JL21G-60
公称力 Nominal Pressure			KN	160	250	450	600
公称力行程 Nominal Pressure Stroke			mm	1.5	1.5	1.5	1.5
滑块行程 Stroke of Slide			mm	20	20	30	30
行程次数 Stroke			S.P.M	150~500	150~500	150~450	150~400
最大装模高度 Max.Die Set Height			mm	200	220	250	280
装模高度调节量 Die Height Adjustment			mm	50	50	50	50
喉口深度 Depth of Throat			mm	160	190	235	270
立柱间距离 Distance Between Uprights			mm	260	300	350	400
滑块底面 Bottom Size of Slide	左右 L-R	mm		390	440	500	580
	前后 F-B	mm		240	270	300	350
模柄孔 Size of Opening in Table	直径 Diameter	mm		Φ40	Φ40	Φ40	Φ50
	厚度 Thickness	mm		70	70	70	85
工作台板 Size of Table	左右 L-R	mm		600	660	720	850
	前后 F-B	mm		300	360	450	520
主电机功率 Main Motor Power			KW	3	4	7.5	11
外形 Overall Dimensions	左右 L-R	mm		900	945	1080	1245
	前后 F-B	mm		1452	1475	1620	1890
	高 Height	mm		1920	2045	2405	2675

# YCH/Y2H/YG1 罐盖高速精密压力机

## High-speed Precision Press



### 技术参数 Specifications

名称 Items		技术参数 Technical Data	型号 Model	YCH-125	YPH-100	Y2H-100	YG1-80	YG1-100
公称力 Nominal Pressure			KN	1250	1000	1000	800	1000
公称力行程 Nominal Pressure Stroke			mm	3	3	4	2	2
滑块行程 Stroke of Slide			mm	40	40	100	100	100
行程次数 Stroke			S.P.M	200~600	120~280	180~220	100~200	60~120
最大装模高度 Max.Die Set Height			mm	370	375	380	380	400
装模高度调节量 Die Height Adjustment			mm	6.5	15	100	50	50
滑块提升量			mm	60	65	40	/	/
工作台板 Size of Table	左右 L-R	mm		1371	1380	1220	1300	1300
	前后 F-B	mm		950	1000	804	450	500
滑块底面 Bottom Size of Slide	左右 L-R	mm		1358	1380	1220	1000	1000
	前后 F-B	mm		900	850	660	400	450
立柱间距离 Distance Between Uprights	左右 L-R	mm		1397	1400	1240	2000	2000
	前后 F-B	mm		482	700	560	300	/
主电机功率 Main Motor Power			KW	30	18.5	22	15	11
							22	15



# J31K 闭式快速强力压力机

## Straight Side High-speed Powerful Press

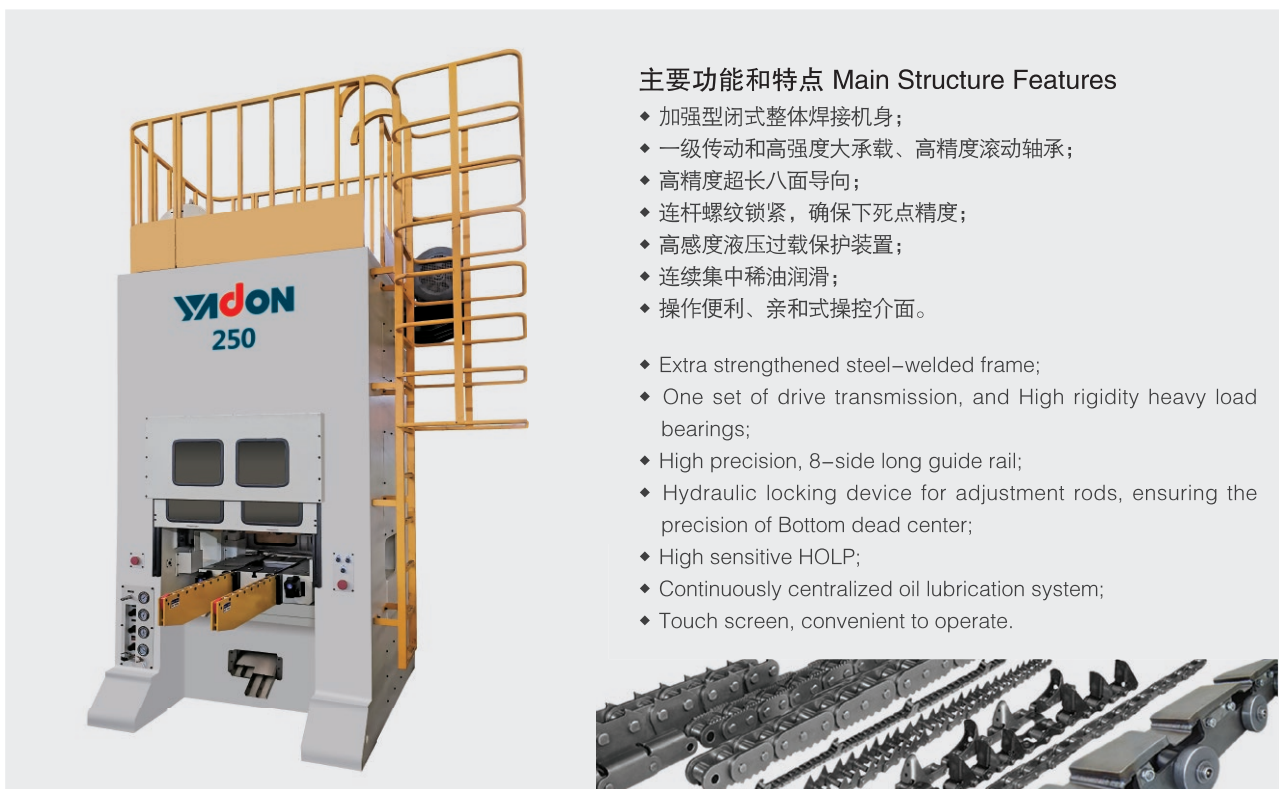

### 主要功能和特点 Main Structure Features

- ◆ 加强型闭式整体焊接机身;
  - ◆ 一级传动和高强度大承载、高精度滚动轴承;
  - ◆ 高精度超长八面导向;
  - ◆ 连杆螺纹锁紧, 确保下死点精度;
  - ◆ 高感度液压过载保护装置;
  - ◆ 连续集中稀油润滑;
  - ◆ 操作便利、亲和式操控介面。
- ◆ Extra strengthened steel-welded frame;
  - ◆ One set of drive transmission, and High rigidity heavy load bearings;
  - ◆ High precision, 8-side long guide rail;
  - ◆ Hydraulic locking device for adjustment rods, ensuring the precision of Bottom dead center;
  - ◆ High sensitive HOLF;
  - ◆ Continuously centralized oil lubrication system;
  - ◆ Touch screen, convenient to operate.



### 技术参数 Specifications

名称 Items		技术参数 Technical Data	型号 Model	J31K-125	J31K-160A	J31K-200A	J31K-250A	J31K-300
公称力 Nominal Pressure		KN		1250	1600	2000	2500	3000
公称力行程 Nominal Pressure Stroke		mm		3	3	4	4	4
滑块行程 Stroke of Slide		mm		30	30	30	30	30
行程次数 Stroke		S.P.M		160~220	140~200	120~200	80~200	110~160
最大装模高度 Max.Die Set Height		mm		280	280	280	300	310
装模高度调节量 Die Height Adjustment		mm		50	50	100	100	100
立柱间距离 Distance Between Uprights	左右 L-R	mm		820	870	900	950	820
	前后 F-B	mm		480	420	430	450	400
滑块底面 Bottom Size of Slide	左右 L-R	mm		750	750	800	880	800
	前后 F-B	mm		600	600	700	750	800
工作台板 Size of Table	左右 L-R	mm		800	850	850	900	800
	前后 F-B	mm		700	700	800	900	800
工作台板孔 Size of Opening in Table	左右 L-R	mm		250	280	280	300	300
	前后 F-B	mm		150	180	160	210	160
主电机功率 Main Motor Power		KW		22	22	30	37	45

# JL21 空调翅片高速冲压自动生产线

## C-type Fin Press Line



### 主要功能和特点 Main Structure Features

- ◆ JL21系列开式空调翅片高速生产线是制冷行业翅片生产的专用生产线, 由开卷机、过油箱、开式高速精密压力机、真空吸盘、集料装置组成;
- ◆ PLC电气集中控制系统、编码器, 满足高速生产线要求的预置切片计数、片计数、集料计数, 及单、双跳功能;
- ◆ 主机配液压过载保护及模高电动调节装置(JL21-45B除外);
- ◆ 稀油自动循环润滑系统, 具有油路报警功能。
- ◆ JL21 series C-type fins press line for the punching of air conditioner fins is specially intended for meeting the requirements for the production of air conditioner fins. The line mainly consists of uncoiler, oil tank, fin press, suction unit, stacker and relevant electrical control system;
- ◆ Imported PLC, counter and contact point free cam controller are adopted to meet the requirements of counting the fins cut collected as well as the function of progress change;
- ◆ Production lines of special specifications can be made subject to the user's requirements.

### 技术参数 Specifications

名称 Items	技术参数 Technical Data	型号 Model	JL21-45C	JL21-63C	JL21-45B	JL21-63B			JL21-80B		
公称力 Capacity	KN		450	630	450	630			800		
滑块行程 Slide of Stroke	mm		40	40	40	60	50	40	60	50	40
行程次数 Stroke	S.P.M		150~250	150~250	100~180	100~150			90~120		
装模高度 Die Height	mm		200~270	210~290	200~270	200~280	205~285	210~290	210~290	215~295	220~300
滑块底面尺寸(长×宽) Bottom Size of Slide (H×W)	mm		500×300	600×350	500×300	600×350			600×350		
工作台板尺寸(长×宽×高) Size of Table(H×W×T)	mm		800×580×100	850×580×110	800×580×80	850×580×90			900×600×100		
材料宽度 Width of Material	mm		300	300	300	300			300		
吸料长度 Sucking Length	mm		1000	1000	1000	1000			1000		
集料高度 Collecting Height of Material	mm		600	600	600	600			600		
卷料内径 Inner Diameter of Material Rolling	mm		Φ75	Φ75	Φ75	Φ75			Φ75		
卷料外径 Outer Diameter of Material Rolling	mm		850	850	850	850			850		
主电动机功率 Main Motor Power	KW		5.5	7.5	5.5	7.5			11		
外形尺寸(长×宽×高) Overall Dimensions(L×W×H)	mm		6500×2500×2330	6500×2500×2500	6500×2500×2500	6500×2500×2800			6600×2500×2800		
封高调整 Die Height Adjustment			电动调整 Motorised								
过载保护 Overload Protect Type			液压过载保护 Hydraulic								
速度调节 Speed Adjustment			变频调速 FDI								
发讯装置 Signal Output			编码器发讯 Rotary Encoder								
角度显示 Angle Display			指针和数字显示 Pilot Pin & Digital Mode								
曲轴轴承 Crank Bearing Way			圆柱滚子轴承 Roller Bearing			铜瓦 Bronze Bush					

注: 特殊规格可根据用户要求制造。



# YKC 空调翅片高速冲压自动生产线

## H-type Fin Press Line



### 主要功能和特点 Main Structure Features

- ◆ 组成：展料架、过油装置、气动初始送料、闭式高速精密压力机、吸料装置、集料装置、电气控制系统、气动系统、液压系统；
  - ◆ 主机调速及真空吸盘采用变频控制；
  - ◆ 滑块液压提升功能，方便模具调试；
  - ◆ 具有集料错误、无油报警、无料检测等保护功能；
  - ◆ 液压过载保护装置，保护压力机和模具安全，使用方便；
  - ◆ 快速换模装置，换模更方便、快捷；
  - ◆ 浓油循环润滑系统，具有油路报警功能，确保机床顺利运行；
  - ◆ PLC电气集中控制系统确保生产线各种功能执行，人机界面，方便操作；
  - ◆ 可选配自动吹废料装置。
- ◆ Compositions: Uncoiler, Oil tank, Air Feeder, Fin press, suction unit and stacker, Electric control system, Air system, Hydraulic system;
  - ◆ The slide of press has hydro-lifting function which will be convenient for dies installation/commissioning;
  - ◆ Press speed & vacuum stucker is controlled by converter;
  - ◆ Collector has protecting system for fault operation No material warning, No oilwarning;
  - ◆ Hydraulic overload protection for main machine;
  - ◆ Equipped with hydraulic rapid-dies changing device, making dies change more quickly and convenient;
  - ◆ Machine-human interface and PLC electrical control system ensuring the reliable operation of the automatic punching.



### 技术参数 Specifications

名称 Items	技术参数 Technical Data	型号 Model	YKC-18-45	YKC-24-63	YKC-24A-63	YKC-36-80	YKC-36A-100	YKC-48A-125	YKC-48H-125	YKC-60A-160	YKC-160	YKC-200
公称力 Capacity	KN		450	630	630	800	1000	1250	1250	1600	1600	2000
滑块行程 Slide of Stroke	mm		40	60 50 40	60 50 40	40	40	40	30	40	80 70 60	80 70 60
行程次数 Stroke	S.P.M		150~300	150-230 150-260 150-300	150-230 150-260 150-300	150~300	150~300	150~300	150~400	150~300	150-200 150-220 150-230	150-200 150-220 150-230
装模高度 Die Height	mm		260~310	260~310	260~310	280~330	280~330	280~330	280~330	280~330	280~330	280~330
滑块提升量 Slide Lifting Height	mm		80	80	80	100	120	130	130	150	130	130
滑块底面尺寸(长×宽) Size of Slide (L×W)	mm		720×780	800×920	1100×920	1055×1220	1300×1190	1500×1350	1500×1350	1450×1540	1300×1190	1300×1190
工作台板尺寸(长×宽) Size of Table(H×L)	mm		1300×770	1350×900	1600×900	1600×1200	1800×1200	2000×1360	2000×1360	2000×1500	2000×1200	2000×1200
材料宽度 Width of Material	mm		400	550	550	820	820	1080	1080	1200	500	500
吸料长度 Sucking Length	mm		1000	1000	1000	900	900	900	900	900	900	900
集料高度 Collecting Height of Material	mm		普通Normal720mm 升降Lift900mm									
卷料内径 Inner Diameter of Material Rolling	mm		Φ150	Φ150	Φ150	Φ150	Φ150	Φ150	Φ150	Φ150	Φ480-Φ550	Φ480-Φ550
卷料外径 Outer Diameter of Material Rolling	mm		Φ1000	Φ1000	Φ1000	Φ1200	Φ1200	Φ1200	Φ1200	Φ1200	Φ1200	Φ1200
主电动机功率 Main Motor Power	KW		7.5	7.5	11	15	18.5	22	22	22	22	22
外形尺寸(长×宽×高) Overall Dimensions(L×W×H)	mm		7500×3500×3200	7500×3500×3500	10000×4000×3200	10000×4000×3500	10000×4000×3500	10000×4500×3800	10000×4500×3800	10000×4800×3800	10000×4000×3500	10000×4000×3500
备注 Remarks			曲轴纵放，单连杆结构 Single cranks structure, and the cranks are installed from front to rear				曲轴纵放，双连杆结构 Double cranks structure, and the cranks are installed from front to rear					
换模装置/初始送料装置 Die Change Device/Initial Feeding Device			选配 Optional				标配 Standard					
光电保护装置 Curtain Sensor			选配 Optional				选配 Optional					



# YKP 肘杆式精压机

## Knuckle Precision Press



### 主要功能和特点 Main Structure Features

- ◆ 适用浅挤压、精整、压印等冲压工艺；
  - ◆ 滑块肘杆结构，下死点停留时间长；
  - ◆ 提升冲压件精度及品质稳定性；
  - ◆ 框架式钢板焊接机身；
  - ◆ 低振动、低噪音、高精度；
  - ◆ 干式气动摩擦离合器；
  - ◆ 高灵敏度液压过载保护；
  - ◆ 稀油自动润滑；
  - ◆ PLC、机械凸轮控制，操作便利。
- ◆ Suitable for shallow extrusion, fine sizing and coining processes;
  - ◆ Slide is of knuckle structure, BDC longer retention time;
  - ◆ Improve punching accuracy and quality stability;
  - ◆ Steel-welded frame;
  - ◆ Low vibration, low noise and High precision;
  - ◆ Dry type pneumatic clutch-brake unit;
  - ◆ High sensitive HOLF;
  - ◆ Automatic oil cycle lubrication system;
  - ◆ PLC, cam controller, convenient to operate.

### 技术参数 Specifications

名称 Items	技术参数 Technical Data	型号 Model	YKP-250	YKP-400	YKP-630	YKP-800	YKP-1000
公称力 Nominal Pressure		KN	2500	4000	6300	8000	10000
公称力行程 Nominal Pressure Stroke		mm	2	2	3	4	6
滑块行程 Stroke of Slide		mm	120	130	130	140	160
行程次数 Stroke		S.P.M	50	50	40	40	35
最大装模高度 Max.Die Set Height		mm	320	330	330	340	500
装模高度调节量 Die Height Adjustment		mm	15	15	15	15	15
立柱间距离 Distance Between Uprights		mm	650	700	740	780	960
滑块底面 Bottom Size of Slider	左右 L-R	mm	550	620	640	700	880
	前后 F-B	mm	400	420	450	470	600
工作台板 Size of Table	左右 L-R	mm	600	640	660	720	900
	前后 F-B	mm	600	660	640	800	900
主电机功率 Main Motor Power		KW	15	18.5	22	30	45

# YKL1 快速返程肘杆精密压力机

## Link Drive Knuckle Precision Press



### 主要功能和特点 Main Structure Features

- ◆ 适用板材冷锻、拉伸、精密下料、净成型及板材冲锻复合成型加工；
  - ◆ 加强型框架式高刚性机身；
  - ◆ 高速下降、低速加工、高速回程特性；
  - ◆ 确保金属制品的塑性成型；
  - ◆ 高精度、高生产性的实现；
  - ◆ 生产时振动和噪音大幅减小；
  - ◆ 延长模具寿命，减少模具维修。
- ◆ Suitable for cold forging, drawing, fine blanking, net forming and punching-forging compound forming of metal sheets;
  - ◆ Extra strengthened High rigidity frame;
  - ◆ Realize quick down, low speed process and then quick return process;
  - ◆ Guarantee plastic forming of metal workpieces;
  - ◆ High precision and High production efficiency;
  - ◆ Reduce vibration and noise while producing;
  - ◆ Prolong die life and reduce die maintenance.

### 技术参数 Specifications

名称 Items	技术参数 Technical Data	型号 Model	YKL1-200	YKL1-315	YKL1-400	YKL1-500	YKL1-650
公称力 Nominal Pressure		KN	2000	3150	4000	5000	6500
公称力行程 Nominal Pressure Stroke		mm	4.8	8	8	8	8
滑块行程 Stroke of Slide		mm	120	150	150	150	150
行程次数 Stroke		S.P.M	25-45	20-40	20-40	20-40	20-40
最大装模高度 Max.Die Set Height		mm	450	450	450	450	450
装模高度调节量 Die Height Adjustment		mm	50	80	80	80	80
工作台板 Size of Table	左右 L-R	mm	1300	1300	1300	1300	1300
	前后 F-B	mm	970	970	1000	1000	1000
滑块底面 Bottom Size of Slide	左右 L-R	mm	1300	1300	1300	1300	1300
	前后 F-B	mm	970	970	1000	1000	1000
立柱间距离 Distance Between Uprights		mm	1350	1350	1350	1350	1350
主电机功率 Main Motor Power		KW	15	22	30	37	45
供给气压 Air supply		MPa	5.5	5.5	5.5	5.5	5.5



# YFB 精冲机

## Fine Blanking Press



### 主要功能和特点 Main Structure Features

- ◆ 生产效率高，制品品质稳定；
  - ◆ 高刚性框架式焊接机身；
  - ◆ 主滑块为高精度超长八面导向；
  - ◆ 主活塞双向导向；
  - ◆ 油缸表面特殊处理；
  - ◆ 高耐磨性密封滑动部件；
  - ◆ 上下备有中心支柱，增强对模具的支撑；
  - ◆ 上死点配有机械装置和电气检测双重限位装置；
  - ◆ 异物检测和叠料保护功能；
  - ◆ 独立液压泵站，弹性联轴节连接；
  - ◆ 制品取出为空气自动吹出或机械手取出；
  - ◆ 非接触式电控系统，节约空间，操作简便；
  - ◆ 选配：移动工作台、自动锁模等装置。
- ◆ High production efficiency and stable quality;
  - ◆ High rigidity steel-welded frame;
  - ◆ 8-side long guide rail;
  - ◆ Main piston has double guides;
  - ◆ Surface of oil cylinders with special treatment;
  - ◆ Airproof sliding part with High wearing quality;
  - ◆ Equipped with centre strut which enhance the support of die;
  - ◆ The top dead center is equipped with mechanical device and electrical detector;
  - ◆ Extraneous matter Automatic detector can protect the mould from improper damage;
  - ◆ Hydraulic pump with absolute construction and connected with the intermediate tubing by elastic coupling;
  - ◆ Adopt air blowout to take out the work;
  - ◆ Noncontact program control system can save the space, also easy to operate;
  - ◆ Optional components: movable table、Automatic locking device, etc.

### 标准配置 Standard Accessories

- ◆ 送料/拉料机  
送料/拉料机由伺服电机控制，根据加工材料的不同对控制参数进行调整
- ◆ 精冲油涂敷器  
通过旋转滚筒对精冲材料上下表面均匀涂敷精冲油，保证精冲件的质量及模具寿命
- ◆ 废料剪切机  
根据需要，在生产中自行设定剪切频次，方便对废料的收集
- ◆ 换模支架  
折叠式换模支架，方便模具的安装与拆卸，保证操作者安全

### 选择配置 Optional Accessories

- 开卷校平机  
根据规格进行选配
- 液压式夹模器  
根据模具及安装位置进行选择，可提高换模效率
- 油雾分离器  
吸除工作现场的灰尘及油雾净化工作环境
- 产品（精冲零件）输送机  
通过传送带将从精冲机吹除的精冲零件输送到规定位置

### 技术参数 Specifications

名称 Items	技术参数 Technical Data	型号 Model	YFB-160	YFB-250	YFB-320	YFB-400	YFB-500	YFB-650	YFB-800	YFB-1000
总压力 Total Pressure	KN		1600	2500	3200	4000	5000	6500	8000	10000
压边力 V-ring Force	KN		800	1200	1600	2000	2500	3200	4000	5000
反压力 Counter Force	KN		400	600	800	1000	1250	1600	2000	2500
卸料力 Stripping Force	KN		150	400	500	700	900	1000	1400	1600
顶件力 Knockout Force	KN		80	200	250	350	450	500	700	800
剪切力 Blanking Force	KN		30	400	400	400	400	400	650	650
滑块行程 Stroke Length	mm		60~140	140~220	140~220	140~220	200~280	200~280	200~280	200~280
滑块行程次数 Stroke	S.P.M		50	50	50	50	50	50	45	40
反压行程 Counter Stroke	mm		25	30	30	40	40	40	40	40
冲裁速度 Blanking Speed	mm/s		5~70	5~70	5~60	5~60	5~60	5~60	5~50	5~50
闭合速度 Approach Speed	mm/s		200	200	200	200	200	200	200	200
回程速度 Return Speed	mm/s		200	200	200	200	200	200	200	200
送料步距 Feeding Length	mm		1~999	1~999	1~999	1~999	1~999	1~999	1~999	1~999
送料精度 Feeding Precision	mm		±0.1	±0.1	±0.1	±0.1	±0.1	±0.1	±0.1	±0.1
条料长度 Sheet Length	mm		1700	1700	2000	2000	2000	2500	2800	2800
条料宽度 Sheet Width	mm		20~200	20~200	40~280	40~280	40~350	40~350	40~450	40~450
条料厚度 Sheet Thickness	mm		16	16	16	16	16	16	16	16
总功率 Total Power	KW		65	95	105	115	130	155	180	200
主电机功率 Main Drive	KW		30	37	55	65	75	90	110	132
油箱容量 Oil Tank Capacity	L		1600	2000	2000	2000	2500	2500	3000	3000

### 模具安装尺寸

名称 Items	技术参数 Technical Data	型号 Model	YFB-160	YFB-250	YFB-320	YFB-400	YFB-500	YFB-650	YFB-800	YFB-1000	
上部工作台 Upper Adapter Plant			固定式 Fixed								
上工作台A Upper Bolster A			500	650	800	850	900	1000	1100	1150	
上工作台B Upper Bolster B			500	600	700	750	850	900	1000	1100	
上工作台C Upper Bolster C			75	75	75	75	75	75	75	75	
上工作台D Upper Bolster D			100	100	100	100	100	100	100	100	
下部工作台 Lower Adapter Plant			固定式 Fixed								
下工作台E Lower Bolster E			500	650	800	850	900	1000	1100	1150	
下工作台F Lower Bolster F			750	900	950	1000	1000	1050	1200	1300	
下工作台G Lower Bolster G			75	75	75	75	75	75	75	75	
下工作台H Lower Bolster H			100	100	100	100	100	100	100	100	
适配环直径Du/DI Dia of Insert Ring Plant			250	280	400	400	400	400	500	500	
适配环高度TU/TL Height of Insert Ring Plant			60	80	80	80	80	80	120	120	
下部工作台 Lower Adapter Plant			移动换模式 Moving								
下工作台X Lower Bolster X			420	550	650	750	750	800	950	950	
下工作台Y Lower Bolster Y			500	650	750	800	800	800	950	950	
条料长度 Sheet Length			80	100	100	100	100	100	140	140	
条料宽度 Sheet Width			230	300	300	300	310	350	380	380	
条料厚度 Sheet Thickness			80	110	110	110	110	140	140	140	
总功率 Total Power			0.01	0.01	0.01	0.01	0.01	0.01	0.01	0.01	

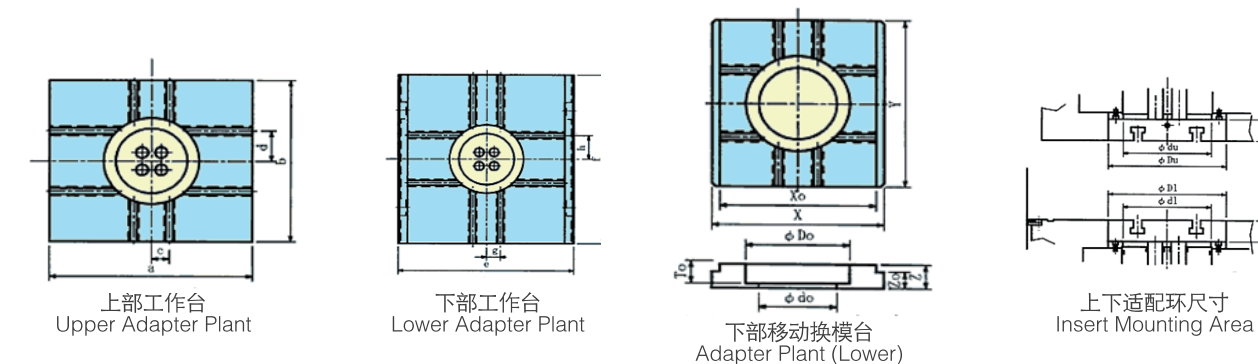



# MP 高速精密热模锻压力机

## Hot Forging Press



### 技术参数 Specifications

名称 Items		技术参数 Technical Data	型号 Model	MP-400	MP-630	MP-800	MP-1000	MP-1250	MP-1600	MP-2000	MP-2500
公称压力 Capacity		KN		4000	6300	8000	10000	12500	16000	20000	25000
滑块行程 Stroke of Slide		mm		180	220	230	250	250	280	300	320
滑块行程次数 Stroke		S.P.M		110	110	100	100	90	85	85	70
有效作业行程次数 Effective SPM Per Minute		S.P.M		18	18	16	16	15	15	15	12
最大装模高度 Max.Die Set Height		mm		400	440	600	650	700	800	900	1000
装模高度调节量 Die Height Adjustment		mm		10	10	10	12	12	16	20	22
工作台 Size of Table		左右 L-R	mm	620	690	850	850	1050	1050	1210	1400
		前后 F-B	mm	900	1000	1060	1120	1170	1400	1530	1700
滑块底面 Bottom Size of Slide		左右 L-R	mm	600	670	820	820	1030	1030	1180	1360
		前后 F-B	mm	660	700	890	930	1010	1140	1260	1310
主电机功率 Main Motor Power		KW		37	45	55	75	75	90	110	132
上顶出力 Upper Ejection Force		KN		25	32	40	50	60	80	100	125
上顶出行程 Upper Ejection Stroke		mm		20	24	26	30	32	37	40	44
下顶出力 Lower Ejection Force		KN		85	95	120	150	200	240	300	375
下顶出行程 Lower Ejection Stroke		mm		20	24	26	30	32	37	40	44
冲床外形 Overall Dimensions		左右 L-R	mm	3500	3600	3700	3800	3900	4000	4300	5000
		前后 F-B	mm	2900	3000	3000	3200	3350	3500	3900	4000
		高 Height	mm	5000	5200	5700	6070	7000	7050	7500	8000

注：标配机械式顶料装置，可选配液压式顶料装置。

### 主要功能和特点 Main Structure Features

- ◆ 采用高刚性钢板焊接分体机身，带闷车解除功能；
  - ◆ 飞轮惯量大，输出能量高，适合温热锻造成型；
  - ◆ 双支点连杆和加长导轨，抗偏载能力强，适合多工位锻造，与步进梁或机器人等组成自动化锻造生产线；
  - ◆ 滑块速度快，模具和工件接触时间短，延长模具寿命；
  - ◆ “X”型导轨，导轨间隙热敏度小；
  - ◆ 封闭高度调节电动调节，封闭高度数字显示；
  - ◆ 离合器和制动器采用浮动镶块气动摩擦式结构；
  - ◆ 具有润滑监控、吨位监控、轴温监控、故障显示、曲轴转角检测和系统运行状态显示功能；
  - ◆ 触摸显示屏，便于操作和参数设置；
  - ◆ 选配步进梁、机器人、隔振系统等。
- ◆ High rigidity split steel welded body,unlock type of hydraulicoverload protection;
  - ◆ With high inertia flywheel and high output energy, so it is suitable for hot forging and forming;
  - ◆ With double-pivot link and extended guide rail and strong resistance to offset load, it is suitable for multi-station forging, and it can form an automated forging production line with progressive arms or robot;
  - ◆ Fast slider speed, short touching time between die and work pieces, which can prolong the service life of die;
  - ◆ “X”-type guide rail, and thethermal sensitivity of gap between guides is low;
  - ◆ Shut height adjustment is motorized and digital display the height;
  - ◆ Clutch and brake are equipped with floating insert pneumatic friction structure;
  - ◆ Have functions of lubrication monitoring, tonnage monitoring, shaft temperature monitoring, fault display, crank angle detection and system operating status display;
  - ◆ Touch screen ( HMI ) for easy and conveniently operating and parameter setting;
  - ◆ Optional progressive arm, robot, cushion, etc.



# MGP 高速精密热模锻压力机

## Hot Forging Press



### 主要功能和特点 Main Structure Features

- ◆ 800T~1600T采用高刚性分体钢板焊接机身，2500T~6300T采用高刚性宽台面分体铸造机身，带闷车解除功能；
- ◆ 偏心轴平衡结构，压力机振动小，配置一级齿轮传动，扭矩大传动平稳；
- ◆ 双支撑宽连杆和加长导轨，抗偏载能力强，适合多工位锻造，与步进梁或机器人等组成自动化锻造生产线；
- ◆ 滑块速度快，模具和工件接触时间短，延长模具寿命；
- ◆ “X”型导轨，导轨间隙热敏度小，或4000T以上采用“O”型导轨；
- ◆ 封闭高度调节电动调节，封闭高度数字显示；
- ◆ MGP-6300采用摩擦片式离合器、MGP-2500以上采用齿导向摩擦片式制动器，2500以下采用摩擦块式制动器；
- ◆ MGP-3150、4000、6300大齿轮内滚动轴承采用自动润滑，确保轴承寿命长；
- ◆ MGP-3150、4000、6300采用新式液压顶料装置，顶料力大，行程大，顶料平稳可靠，适合多工位自动化生产；
- ◆ 具有润滑监控、吨位监控、轴温监控、故障显示、曲轴转角检测和系统运行状态显示功能；
- ◆ 2500T及以下采用浓油自动润滑，2500T以上采用稀油自动润滑（导轨除外）；
- ◆ 触摸显示屏，便于操作和参数设置；
- ◆ 选配步进梁、机器人、隔振系统等。

- ◆ For tonnage between 800T-1600T, the frame is a separated structure made of high rigidity welded steel. For tonnage between 2500T-6300T, frame is also a separated structure, but made of cast iron instead, with unlock type of hydraulicoverload protection;
- ◆ With high inertia flywheel and high output energy, this series machines are suitable for hot or warm forging process;
- ◆ With connection rod of two supporting points type and lengthened guide ways, this series machines are good at offset loading and easy to being equipped with progressive arms or robot arms, perfectly meeting multi-station progressive forging process;
- ◆ The slide speed is fast, as a result it shortens the touching time to the forging parts and lengthens the die service life;
- ◆ “X” type guide ways are adopted, its heat sensitivity for the clearance is low;
- ◆ The shut height adjustment is motorized;
- ◆ MGP-3150, 4000, 6300 equip automatic lubrication on internal rolling bearings of large gear, to ensure bearing service life;
- ◆ MGP-3150,4000,6300 adopts a new type of hydraulicknock-out device, which has large force, long stroke, stable and reliable capacity, suitable for transfer automatic production;
- ◆ Having the functions such as lubrication monitor, tonnage monitor, bushing temperature monitor, trouble shooting displayer, crank angle detector, system running displayer and so on (as optional);
- ◆ Press tonnage below 2500T adopts auto grease lubrication, over 2500T adopts auto liquid lubrication(except the guiding rail)
- ◆ With touch-screen (HMI), making the machine easily and conveniently to operate or set parameters;
- ◆ Optional accessories include progressive arm, robot arm, anti-vibration mounts, etc.

### ◆ 锻造工艺模拟 Process Simulation

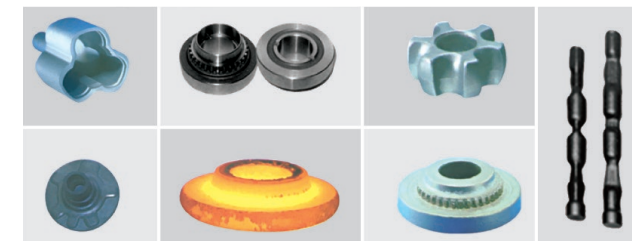
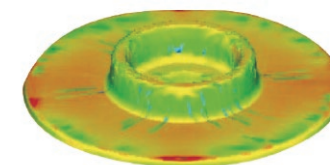
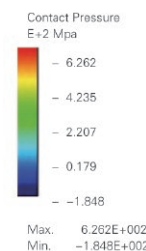

### 技术参数 Specifications

名称 Items		技术参数 Technical Data	型号 Model	MGP-800	MGP-1000	MGP-1250	MGP-1600	MGP-2500	MGP-3150	MGP-4000	MGP-6300
公称压力 Capacity		KN		8000	10000	12500	16000	25000	31500	40000	63000
滑块行程 Stroke of Slide		mm		230	250	250	280	320	340	400	450
滑块行程次数 Stroke		S.P.M		70	70	70	70	60	60	55	50
有效作业行程次数 Effective S.P.M Per Minute		S.P.M		16	16	15	15	12	12	12	10
最大装模高度 Max.Die Set Height		mm		600	650	700	800	1000	1000	1400	1650
装模高度调节量 Die Height Adjustment		mm		10	12	12	16	10	10	10	12
工作台面 Size of Table	左右 L-R	mm		850	850	1050	1050	1400	1600	1700	1900
	前后 F-B	mm		1060	1120	1250	1400	1700	1700	1800	2200
滑块底面 Bottom Size of Slide	左右 L-R	mm		820	820	1030	1030	1360	1550	1660	1860
	前后 F-B	mm		890	930	1010	1140	1310	1480	1600	1800
主电机功率 Main Motor Power		KW		55	75	90	110	160	200	280	355
上顶出力 Upper Ejection Force		KN		40 机械式	50 机械式	60 机械式	80 机械式	125 液压式	150 液压式	200 液压式	300 液压式
上顶出行程 Upper Ejection Stroke		mm		26	30	32	37	44	48	52	60
下顶出力 Lower Ejection Force		KN		120 机械式	150 机械式	200 机械式	240 机械式	375 液压式	500 液压式	600 液压式	800 液压式
下顶出行程 Lower Ejection Stroke		mm		26	30	32	37	60	80	80	100
压机外形 Overall Dimensions	左右 L-R	mm		3700	3800	3900	4000	5400	5800	5900	6000
	前后 F-B	mm		3450	3500	3500	3700	4600	5100	5400	7500
	高 Height	mm		5700	6070	7000	7050	8400	8900	10500	11000

注：MGP-800、1000、1250、1600标配机械式顶料装置，可选配液压式。  
MGP-2500、3150、4000、6300标配液压式顶料装置。



# YHF 热模锻压力机

## Series Hot Forging Press

### □ 无连杆驱动

Drive without connecting rod

整机高度降低25%

机床整体刚度增加45%

滑块与偏心轴传力面宽，抗偏载能力强

The height of the whole machine is reduced by 25%  
The overall rigidity of the machine is increased by 45%  
The slide and eccentric shaft have wide force transmission surface and strong ability to resist eccentric load

### □ 液压上下顶料装置

Hydraulic upper and lower ejector

### □ 人字齿轮传动系统

Herringbone gear transmission system

### □ 可靠的稀油润滑系统

Reliable oil lubrication system

### □ 滑块导向系统

Slide guide system

滑块导向长至包络曲轴，导向精度高

高灵活性滑块导向调整机构

高稳定性重型滑动轴承

The slide guide is long enough to envelop the crankshaft, with high guide accuracy  
High flexibility slide guide adjustment system  
High stability heavy sliding bearing

### □ 高刚性滑块调节装置

High rigidity slide adjust device

独特专利滑块调节机构

液压马达驱动

生产过程中可进行调节

Unique patented slide adjustment system  
Hydraulic motor drive  
It can be adjusted during production

### □ 高灵敏离合制动器

High sensitivity clutch brake

液压驱动离合与制动器

机床上死点停止精度  $\pm 4^\circ$

Hydraulically driven clutch and brake  
Top dead center stop accuracy of machine  $\pm 4^\circ$

### □ 安全单平衡缸

Safety single balance cylinder

独特的平衡缸结构，系统运行安全、无压力损失

独特的安装理念，最好效果地平衡滑块和模具重量

Unique balance cylinder structure, safe system operation and no pressure loss  
Unique assembling concept, best balance the weight of slide and die

### □ 能量回收系统（选配）

Energy recovery system (optional)

提高1.8倍以上行程次数

节省约40%的电量

极大减少机械零件的磨损

Increase the strokes by more than 1.8 times  
Save about 40% of power  
Greatly reduce the wear of mechanical parts

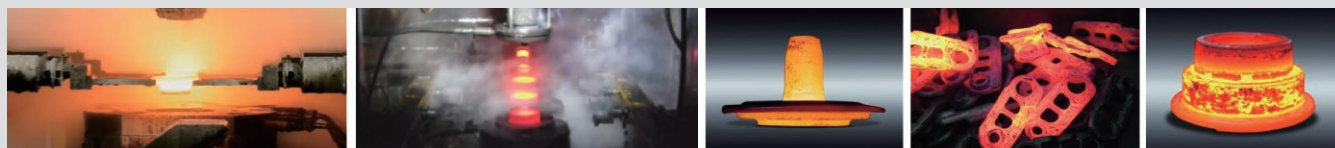

## 技术参数 Specifications

名称 Items	技术参数 Technical Data	型号 Model	YHF-750V	YHF-1000V	YHF-1300V	YHF-1600V	YHF-1800V	YHF-2000V	YHF-2500R	YHF-3150R	YHF-4000R	YHF-5000R	YHF-6300R	YHF-8000R	YHF-16000R				
公称力 Nominal Pressure		kN	7500	10000	13000	16000	18000	20000	25000	31500	40000	50000	63000	80000	160000				
滑块行程次数 Strokes per minute		S.P.M	100	100	90	85	85	85	70	70	55	50	47	45	32				
有效作业行程次数 Effective strokes		S.P.M	30	22	22	15	30	15	30	15	30	15	30	10	20	8	20	6	10
Standard 标准	KERS 能量回收																		
滑块行程 Slide stroke		mm	200	230	230	280	280	300	340	350	450	400	430	500	600				
封高调整量 Slide adjustment		mm	10	16	16	16	16	16	20	20	20	20	25	25	20				
最大装模高度 Max die set height		mm	600	700	900	1100	1100	1200	1500	1500	1600	1600	1600	1600	2100				
立柱左右间距 Distance between uprights (L-R)		mm	750	1000	1000	1100	1100	1300	1400	1400	1600	1600	1800	2000	2550				
立柱前后间距 Side light uprights (F-B)		mm	550	720	750	850	850	960	960	1250	1850	1150	1300	1300	2200				
滑块尺寸 Slide bottom	左右 L-R	mm	710	890	890	970	970	1200	1300	1520	1520	1510	1650	1700	2400				
	前后 F-B	mm	850	1070	1070	1200	1200	1300	1460	1700	1900	1900	2200	2200	3200				
台板尺寸 Bolster size	左右 L-R	mm	750	1000	1000	1100	1100	1300	1360	1630	1600	1600	1800	1800	2500				
	前后 F-B	mm	950	1100	1100	1250	1250	1300	1450	1700	2200	1800	2200	2200	3200				
主电机功率 Main power		kW	45	75	90	110	132	200	250	250	315	315	355	500	800				

注：V一级传动，R二级传动



# J58 伺服直驱电动螺旋压力机

## Servo Direct Drive Electric Screw Press



### 主要功能和特点 Main Structure Features

- ◆ 德国舒勒团队设计，采用独特的伺服直驱技术；
- ◆ 电机转子直接与飞轮连接，无需中间部件驱动，维护方便；
- ◆ 免维护，结构简单，维护保养更方便；
- ◆ 高灵敏度液压过载保护装置（2000T以上）；
- ◆ 主螺杆和飞轮采用独特的无间隙长销连接；
- ◆ 超长“X”型导轨，精度保持性好，抗偏载能力强；
- ◆ 能量控制精确，模具使用寿命更长，产品成形一致性好；
- ◆ 采用人机界面方便用户进行打击能量等参数的设定；
- ◆ 适用于中小型件的模锻、精压、校正、弯曲、压印等工序。



### Main Structure Features

- ◆ Designed by German Schuler team, unique variable-frequency and direct-drive motor is adopted;
- ◆ Motor rotor is directly connected to flywheel, maintenance is much easier without intermediate driving parts;
- ◆ High rigidity frame, small deformation;
- ◆ High sensitivity hydraulic overload protection device;
- ◆ Main bolt and flywheel are connected by clearance-free pin
- ◆ Super long “X” guide rail, high precision retentivity, strong load deviation resistance;
- ◆ Precise energy control, good consistency of products;
- ◆ Human-machine interface facilitates setting of parameters like blow energy and etc.
- ◆ Suitable for die forging, precision punching, calibration, bending, coining and etc.



### 技术参数 Specifications

名称 Items		技术参数 Technical Data	型号 Model	J58-400	J58-700	J58-1000	J58-1600
公称力 Nominal pressure		kN		4000	7000	10000	16000
长期运行许可载荷（中心载荷） Permissible continuous press force (centric load)		kN		6400	11000	16000	26000
总工作能力 Gross working capacity		kJ		32.5	72	130	240
滑块行程 Stroke of Slide		mm		400	430	500	560
行程次数 Stroke		S.P.M		23	20	18	16
最小封闭高度 Distance bed -slide min.		mm		760	730	920	1080
工作台板 Bolster	左右 L-R	mm		620	750	860	1000
	前后 F-B	mm		650	800	920	1080
滑块底面 Slide	左右 L-R	mm		620	750	860	1000
	前后 F-B	mm		650	800	920	1100

注：1600T以下整体焊接机身。  
2000T以上两段式分体铸造机身。

### 技术参数 Specifications

名称 Items		技术参数 Technical Data	型号 Model	J58-2000	J58-2500	J58-3150	J58-4000
公称力 Nominal pressure		kN		20000	25000	31500	40000
长期运行许可载荷（中心载荷） Permissible continuous press force (centric load)		kN		32000	40000	50000	64000
总工作能力 Gross working capacity		kJ		450	560	700	1000
滑块行程 Stroke of Slide		mm		600	630	680	720
行程次数 Stroke		S.P.M		16	15	14	11
最小封闭高度 Distance bed -slide min.		mm		1200	1300	1450	1460
工作台板 Bolster	左右 L-R	mm		1100	1200	1320	1500
	前后 F-B	mm		1180	1280	1400	1900
滑块底面 Slide	左右 L-R	mm		1100	1200	1320	1500
	前后 F-B	mm		1180	1300	1400	1600



# YHQ2 双点精密切边整形压力机

## Two Points Precision Trimming Press



### 主要功能和特点 Main Structure Features

- ◆ 框架整体焊接机身，刚性高，变形量小；
  - ◆ 双点曲轴横放结构，抗偏载能力强；
  - ◆ 滑块导向长，精度高；
  - ◆ 滑块导轨浓油润滑；
  - ◆ 生产效率高；
  - ◆ 作为模锻配套压机，适合在热态或冷态下锻件的冲孔、切边及精整工艺。
- ◆ Whole monoblock steel-welding frame, with high rigidity and less deformation;
  - ◆ Two cranks cross-mounted structure, with good anti-deviated loading capacity;
  - ◆ Long guide ways of slide, with high precision accuracy.
  - ◆ Slide guide rails oil lubricated automatically;
  - ◆ High production efficiency;
  - ◆ As an accessory machine for forging machine, suitable for punching, trimming and sizing process under hot or cold status.

### 技术参数 Specifications

名称 Items	技术参数 Technical Data	型号 Model	YHQ2-200	YHQ2-250	YHQ2-315	YHQ2-400	YHQ2-500	YHQ2-630	YHQ2-800
公称力 Nominal Pressure	KN		2000	2500	3150	4000	5000	6300	8000
公称力行程 Nominal Pressure Stroke	mm		13	13	13	13	13	13	13
滑块行程 Stroke of Slide	mm		200	220	250	250	250	300	350
行程次数 Stroke	S.P.M		50	45	38	35	35	30	30
最大单次节拍	次/分		12	10	10	10	10	10	8
最大装模高度 Max.Die Set Height	mm		500	550	600	650	650	700	700
装模高度调节量 Die Height Adjustment	mm		100	120	120	150	150	150	150
工作台板 Size of Table	左右 L-R	mm	1100	1200	1300	1400	1600	1800	2050
	前后 F-B	mm	750	900	1000	1050	1100	1200	1250
滑块底面 Bottom Size of Slide	左右 L-R	mm	1100	1200	1300	1400	1600	1800	2030
	前后 F-B	mm	750	900	1000	1050	1100	1200	1160
供给气压 Air Supply	MPa		0.5	0.5	0.5	0.5	0.5	0.5	0.5
主电机功率 Main Motor Power	KW		22	30	37	45	55	75	75

# JX21 橡胶瓶塞除边机

## Brim Cutting Machine for Rubber Bottle Stopper



### 主要功能和特点 Main Structure Features

- ◆ JX21-45压力机是医用橡胶瓶塞除边专用机床，系引进意大利技术生产的高性能固定台压力机；
- ◆ 滑块八面导向，运行精度高；
- ◆ 进口品牌离合器和凸轮控制器；
- ◆ 采用带检测功能的双联电磁阀和PLC双回路电控系统。
- ◆ This machine is specially developed for the manufacture of rubber bottle stopper of medical use. It is a high performance press with fixed table involving high technologies from Italy.
- ◆ Eight-side long rectangle guides of the slide in high moving precision and high accuracy, extending the service life of the die.
- ◆ Imported clutch, and the cam controller from Taiwan.
- ◆ Imported electromagnetic valve with testing function and imported PLC double-circuit electric control system.
- ◆ Automatic oil lubricating system and alarm against oil shortage.

### 技术参数 Specifications

名称 Items	技术参数 Technical Data	型号 Model	JX21-45
公称力 Nominal Pressure	KN		450
公称力行程 Nominal Pressure Stroke	mm		4
滑块行程 Stroke of Slide	mm		110
行程次数 Stroke	S.P.M		70-110
单操作最大允许接通次数 Max.Allowable Engaging Time at Single Operation	rpm		20
最大装模高度 Max.Die Set Height	mm		285
装模高度调节量 Die Height Adjustment	mm		50
喉口深度 Depth of Throat	mm		220
立柱间距离 Distance Between Uprights	mm		510
滑块底面(左右×前后) Bottom Size of Slide(L-R×F-B)	mm		500×300
模柄孔(直径×深度) Hole for Punch Shank(Diameter×Depth)	mm		Φ50×60
工作台板(左右×前后) Size of Table(L-R×F-B)	mm		800×420
工作台板厚度 Thickness of Table	mm		80
工作台板孔(左右×前后) Size of Opening in Table(L-R×F-B)	mm		300×260
主电动机功率 Main Motor Power	KW		YCT200-4A/5.5
空气压力 Air Pressure	Kg/cm <sup>2</sup>		0.5
外形(左右×前后×高) Overall Dimensions(L,R×F,B×H)	mm		1080×1385×2655
总重量 Total Weight	Kg		4100