

# Surface Grinder

## EASY NC Series

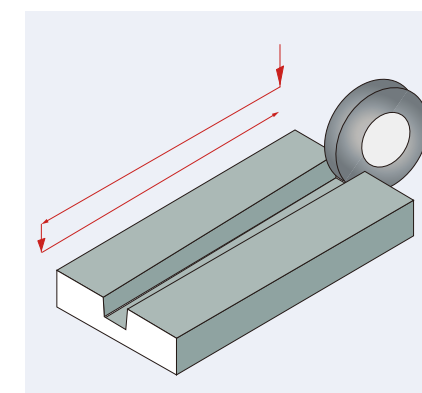
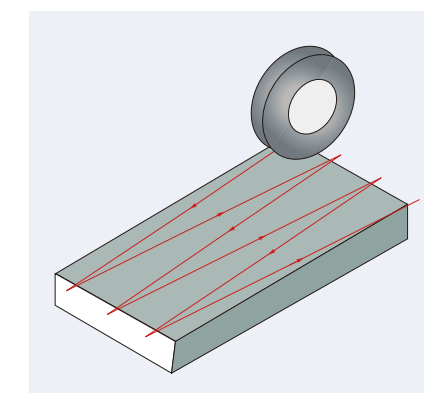
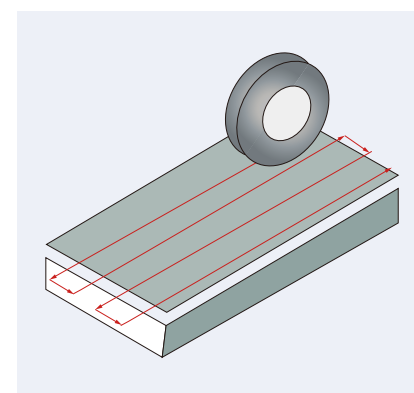

## Grinder Professionals

### *e-tech* USA

6435 Alondra Blvd,  
Paramount, CA 90723  
TEL: +1(562)220-1675  
Mail: [info@supertecusa.com](mailto:info@supertecusa.com)

### *e-tech* Asian Operations Center

No.36, Ln.686, Sec. 4, Chanping Rd.,  
Daya Dist., Taichung City 428  
Taiwan (R.O.C)  
TEL: +886-4-2568-6418  
Mail: [info@etechtw.com](mailto:info@etechtw.com)  
Web: [www.etechtw.com](http://www.etechtw.com)

# 1 EASY Series Surface Grinder NC Type

## Features

Simple operation and high precision surface grinder, the best solution for you!

Specilly built for mold and high-tech electronics industries :

- E-tech Easy series surface grinder present unique grinding accuracy and surface finish, and we offer both saddle and type option for different tasks. The structure design provides high precision and high rigidity results, especially for large parts and creates praising accuracy.
- EASY series supply PLC control panel and color touch screen with strong function and easy operation; furthermore, auto grinding function met the target of time saving and high efficiency.



Saddle type structure  
Model : EASY-1224 \ EASY-1632



Column type structure  
Model: EASY-2040 \ EASY-2448

## CNC Controller

Easy series surface grinder provide PLC control in combination of color touch screen and uer-friendly operation design. Operator can simply set up the grinding amount and be ready to start a grinding cycle. The control system will save the last grinding parameter setting automatically, and operator only have to press "cycle start" button to repeat the previous set parameter and start the cycle again.



## Setting Display

**Main Menu**

**Mode Selection**

CrissCross Step-Cross Plunge

Feed Selection

FRONT REAR LEFT RIGHT

Park Selection

LEFT RIGHT NEXT

**Setting Screen**

location:

Total Stock Removal : \_\_\_\_\_ mm  
 Fine-feed Amount : \_\_\_\_\_ mm  
 Coarse Increment : \_\_\_\_\_ mm  
 Fine Increment : \_\_\_\_\_ mm  
 Sparkout Passes : \_\_\_\_\_  
 Clearance : \_\_\_\_\_  
 Time : \_\_\_\_\_ sec

**Data input keyboard**

7 8 9 CLR  
 4 . 6 ▲  
 1 2 3 ▼  
 0 - ENT

Crossfeed distance and be pre-set, and operator can also choose to set to set the front or rear position to feed from dual sides or one side of the working table. Grinding wheel infeed movement can also be set to start grinding from dual sides or either one side of the working table. The working table longitudinal movement distance can also be set precisely and steady, and operator can also choose to set the start / stop position on the left or right side of the table. (Auto. Dressing attachment can be offered as optional accessory)

## Grinding Cycle

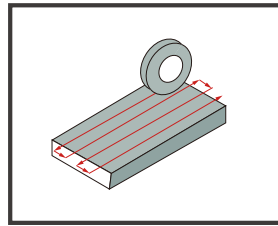

1. Step grinding

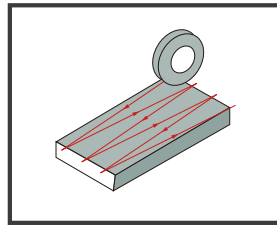

2. Criss-cross grinding

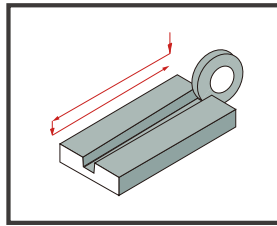

3. Plunge grinding

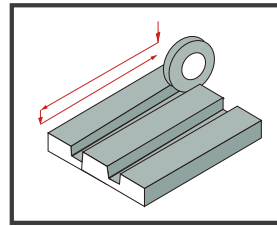

4. Multi-slicing grinding (opt.)

### 3 Column Type Surface Grinder Design Feature

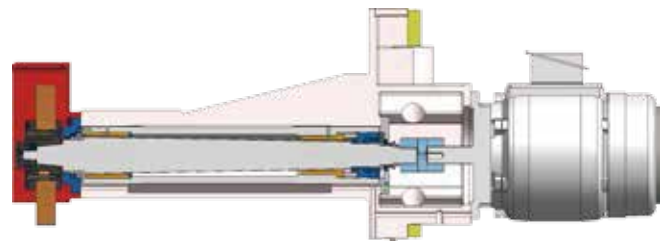

- Hydrodynamic spindle offers steady oil pressure supply to support the spindle. Spindle run-out is less than 0.002mm, and stiffness over 50Kgf/um. This feature is suitable for both light and heavy duty grinding operation. The hydraulic circuit is connected to a pressure sensor, once the oil pressure is too low, the grinding wheel will automatically stopped to prevent causing damage to the spindle.
- Bearing type spindle features high accuracy, non-vibration, low thermal growth. The spindle is equipped with precision angular contact ball bearings and the grease sealed lubrication makes the spindle easy to maintain and ensure of continuous operation. The spindle run-out is less than 0.002mm.
- X / Z Axis guideway lubrication system is equipped with pressure sensing function and make sure enough lubrication pressure is supplied.

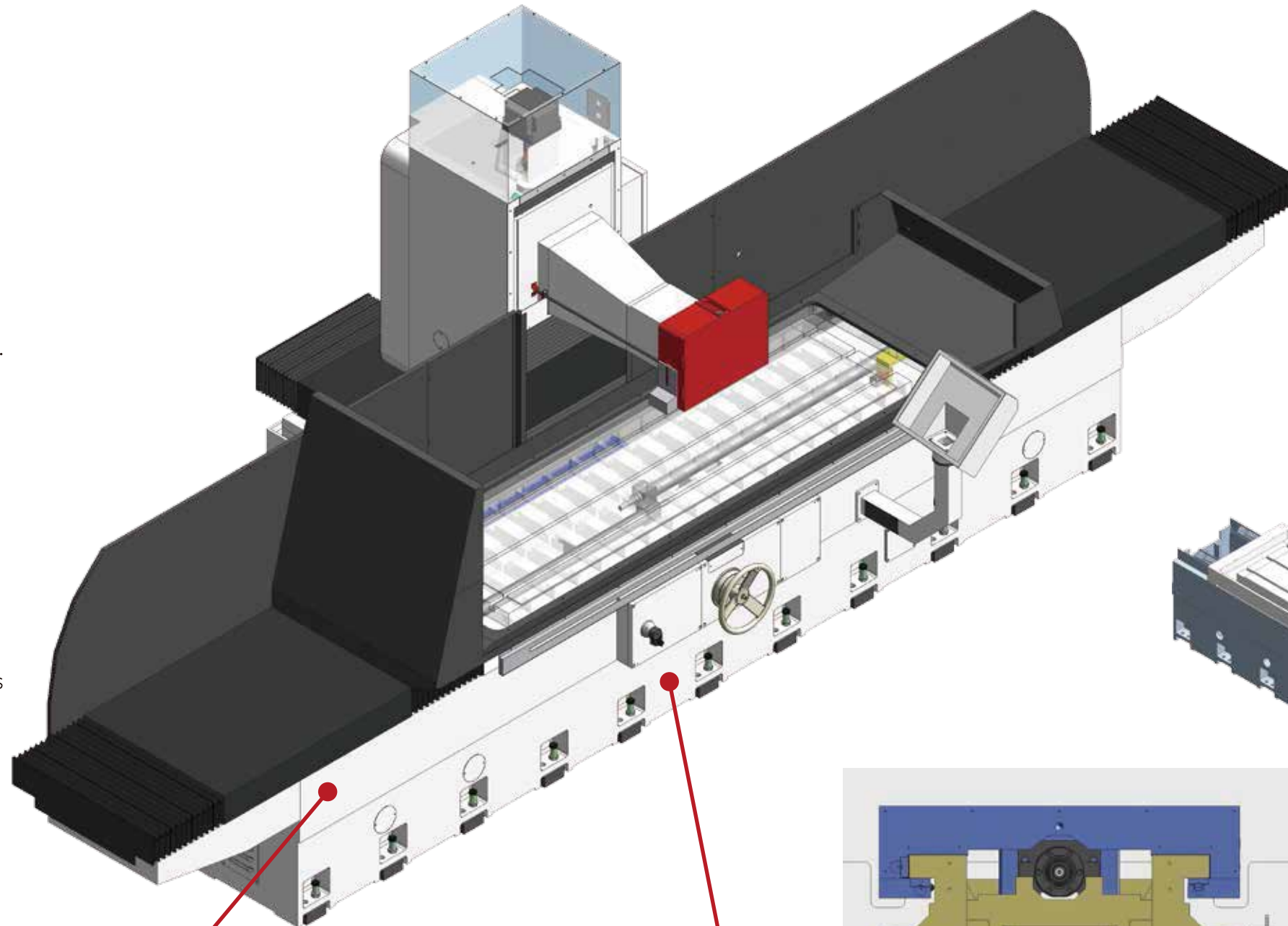

E-tech offers wider and heavier design of the column, which offers high stability and rigidity. The lubrication is supplied independently to extend the lifetime.

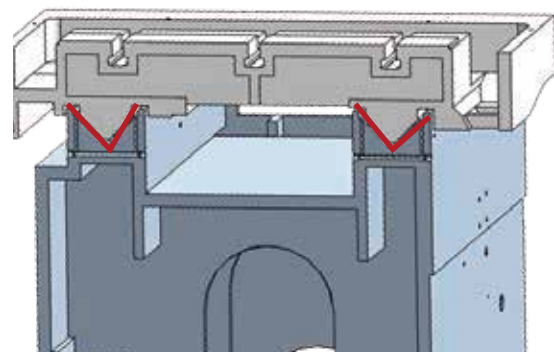
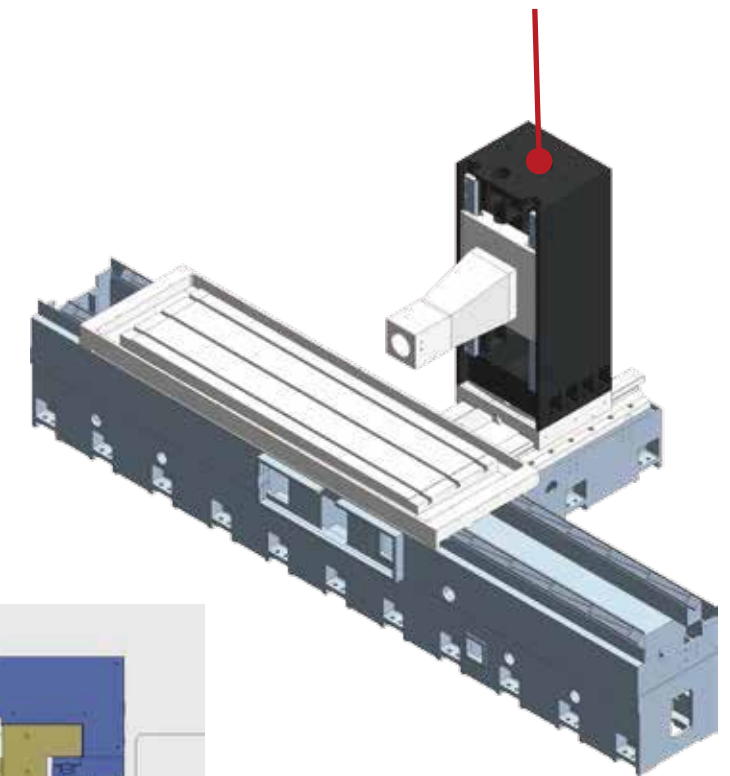

X Axis

#### X Axis Working table guideway double V design

For large parts and heavy duty jobs, the working-table slideways are modified as double V guideways. Deepen and widen the guideways with large span design offers the working table steady and smooth movement.

X Axis guideway is precisely hand scraped, oil film lubrication supplied, and Turcite-B coated to ensure positioning accuracy and long term usage.

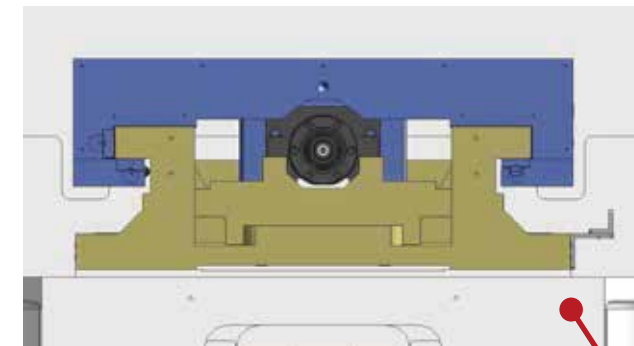

The integral "T" shape base is manufactured from Meehanite casting, with tempering & stress-relief treatment to ensure structure stability and avoid transformation.

The base is 2.5 times longer than the working table, which makes the working table fully supported during the whole travel, and this function also increase the supporting rigidity during grinding operation.

#### Z Axis Saddle Structure

The saddle is precisely scraped and driven by precise ballscrew to move along the box guideway, increasing machine rigidity and extend the machine lifetime.



# 5 Specification : EASY NC Series

Model	Unit	EASY-1224NC	EASY-1632NC	EASY-2040NC	EASY-2060NC	Model	Unit	EASY-2448NC	EASY-2460NC	EASY-2480NC	EASY-24100NC				
<b>General Capacity</b>	Max. grinding length	mm	600	800	1050	1550	<b>General Capacity</b>	Max. grinding length	mm	1250	1550	2050	2550		
	Max. grinding width	mm	300	400	500	500		Max. grinding width	mm	625	625	625	625		
	Distance (from table surface to spindle centerline)	mm	550	550	600	600		Distance (from table surface to spindle centerline)	mm	700	700	700	700		
	Max. load on table (incl. magnetic chuck)	kg	400	580	850	850		Max. load on table (incl. magnetic chuck)	kg	850	850	850	850		
<b>Working table</b>	Table size	mm	300x600	400x800	500x1000	500x1500	<b>Working table</b>	Table size	mm	600x1200	600x1500	600x2000	600x2500		
	T slot dimension x quantity		14x1	14x3	14x3	14x3		T slot dimension x quantity		20x3	20x3	20x3	20x3		
	Distance from table surface to floor	mm	950	950	920	920		Distance from table surface to floor	mm	930	930	930	930		
	Standard magnetic chuck size	mm	300x600	400x800	500x1000	500x1500		Standard magnetic chuck size	mm	600x1200	600x1500	600x2000	600x2500		
	Saddle / Column moving	-	Saddle	Saddle	Column	Column		Saddle / Column moving	-	Column	Column	Column	Column		
<b>Longitudinal Movement</b>	Travel distance	mm	650	850	1100	1600	<b>Longitudinal Movement</b>	Travel distance	mm	1350	1650	2150	2650		
	- X Axis	Table speed	m/min	3~25	3~25	3~25		3~25	- X Axis	Table speed	m/min	3~25	3~25	3~25	3~25
	Manual travel	mm	700	900	X	X		Manual travel	mm	X	X	X	X		
<b>Auto. Cross Movement</b>	Automatic increment feeds	mm	360	460	550	550	<b>Auto. Cross Movement</b>	Automatic increment feeds	mm	725	725	725	725		
	- Z Axis	Rapid travel (60Hz/50Hz)	mm/min	1710/1425	1710/1425	1710/1425		1710/1425	- Z Axis	Rapid travel (60Hz/50Hz)	mm/min	1710/1425	1710/1425	1710/1425	1710/1425
	Min. input unit ( NCII model, opt. )	mm	0.001	0.001	0.001	0.001		Min. input unit ( NCII model, opt. )	mm	0.001	0.001	0.001	0.001		
<b>Manual Cross Movement</b>	Manual travel	mm	370	470	575	575	<b>Manual Cross Movement</b>	Manual travel	mm	725	725	725	725		
	- Z Axis	Handwheel per graduation	mm	0.02	0.02	0.02		0.02	- Z Axis	Handwheel per graduation	mm	0.02	0.02	0.02	0.02
	Handwheel per revolution	mm	5	5	5	5		Handwheel per revolution	mm	5	5	5	5		
<b>Vertical Downfeed</b>	Automatic downfeed travel	mm	400	400	500	500	<b>Vertical Downfeed</b>	Automatic downfeed travel	mm	500	500	500	500		
	- Y Axis	Max. infeed speed	m/min	2.5	2.5	2.5		2.5	- Y Axis	Max. infeed speed	m/min	2.5	2.5	2.5	2.5
	Min. input unit	mm	0.001	0.001	0.001	0.001		Min. input unit	mm	0.001	0.001	0.001	0.001		
	Y axis servo motor	Kw	1	1	1	1		Y axis servo motor	Kw	3	3	3	3		
<b>Grinding Wheel</b>	Wheel size (OD x W x ID)	mm	Ø355x50xØ127	Ø355x50xØ127	Ø405x50xØ127	Ø405x50xØ127	<b>Grinding Wheel</b>	Wheel size (OD x W x ID)	mm	Ø405x50xØ127	Ø405x50xØ127	Ø405x50xØ127	Ø405x50xØ127		
	Spindle speed (60Hz/50Hz)	rpm	1800/1500	1800/1500	1800/1500	1800/1500		Spindle speed (60Hz/50Hz)	rpm	1800/1500	1800/1500	1800/1500	1800/1500		
	Spindle motor	kw	3.75/5.6(opt.)	3.75/5.6(opt.)	5.625/7.5(opt.)	5.625/7.5(opt.)		Spindle motor	kw	11	11	11	11		
	Max. torque	Nm	26/36	26/36	36/49	36/49		Max. torque	Nm	71	71	71	71		
<b>Motor</b>	Hydraulic motor	kw	1.5	1.5	2.25	2.25	<b>Motor</b>	Hydraulic motor	kw	3.75	3.75	5.5	5.5		
	Lubrication motor	kw	0.075	0.075	0.025	0.025		Lubrication motor	kw	0.187	0.187	0.187	0.187		
<b>Packing dimension</b>	(LxWxH)	cm	285x225x249	320x226x255	360x228x255	542x228x255	<b>Packing dimension</b>	(LxWxH)	cm	424x2300x255	542x228x255	600x228x300	700x228x300		
	Net weight	kg	3000	3500	5900	7100		Net weight	kg	6600	8800	10420	10900		
	Gross weight	kg	3500	4500	6900	8600		Gross weight	kg	7600	9800	10920	11700		

\*All machine design and specification are subject to change without prior notice.

## Standard Accessories

Grinding Wheel+wheel flange  
 PLC + Touch Screen + Control Panel  
 Y-axis Ball Screw + Servo Motor  
 Hydraulic System w/cooling fan  
 Operating Manual & Part Lists  
 Leveling Bolts w/ Blocks

Balancing Stand w/Arbor  
 Standard Coolant Tank  
 Semi-enclosure Splash Guard  
 Grinding Wheel Extractor  
 Diamond Dresser & Stand  
 Tools & Tool Box

## Optional Accessories

(Fine Pole) Electromagnetic Chuck w/Auto. Demagnetizer  
 Electromagnetic Chuck w/Auto. Demagnetizer  
 Coolant system with magnetic separator & paper filter  
 Coolant system with magnetic separator  
 Coolant system with paper filter  
 Y & Z Axis (Vertical & Cross) linear scale w/ DRO  
 Y Axis (Vertical) linear scale w/ DRO  
 Overhead Parallel Dressing Attachment (Manual/Hydraulic)  
 "Overhead Parallel Dressing Attachment w/ Automatic Compensation (Stepping motor)"

Permanent Magnetic Rotary Chuck  
 Dual side dressing attachment  
 Spare grinding wheel flange  
 Angle dressing attachment  
 Radius dressing attachment  
 Oil & mist collecting system  
 Grinding wheel inverter  
 Dust collector